

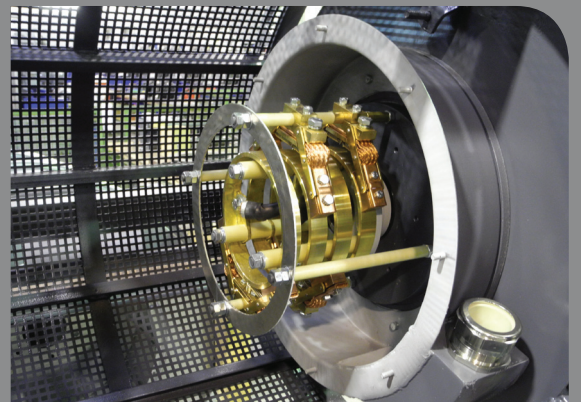

Hartmann & König
STROMZUFÜHRUNGS AG

Slip ring bodies

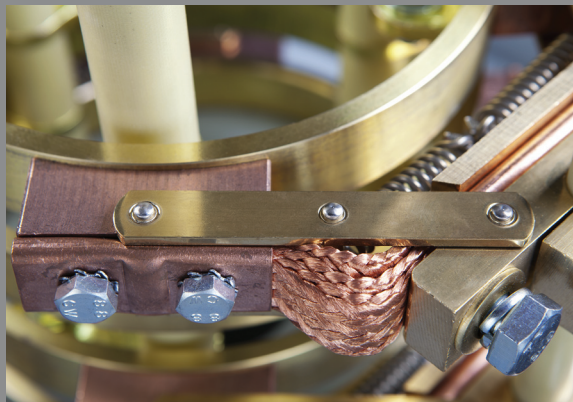
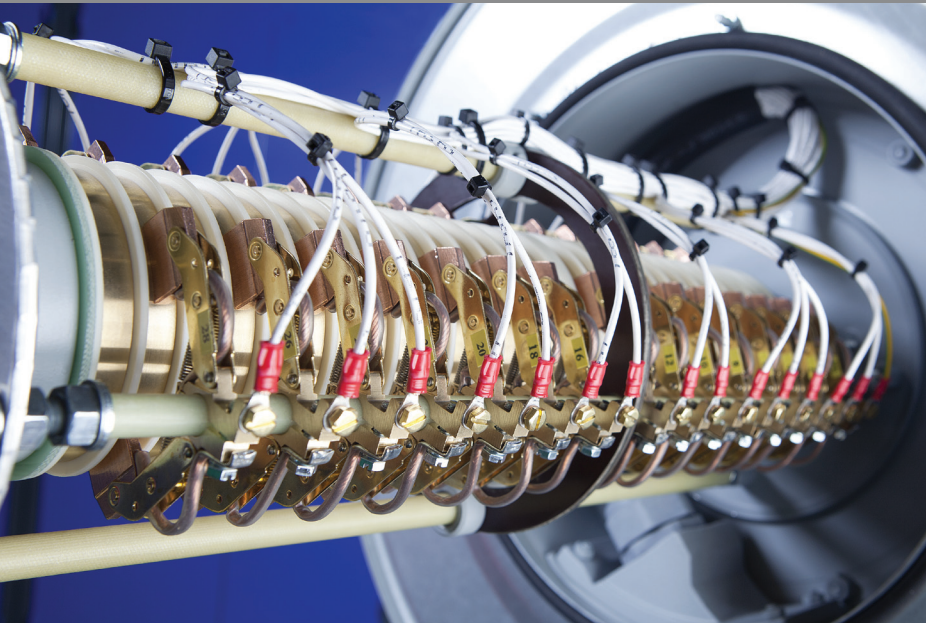

**YOUR PARTNER FOR ENERGY AND DATA TRANSMISSION SYSTEMS
FOR MOBILE CONSUMERS**

CONCEIVE
CONNECT
CONDUCT





Contents

Summary of Types

	Page
Slipring Bodies, Summary of the Types	2 - 3
Block Type Slipring Bodies	4 - 8
Air Gap Type Slipring Bodies	9 - 15
Slipring Bodies, Rotating Open Units, Protection Class IP 00	16 - 18
Slipring Bodies, Rotating Enclosed Units, Protection Class IP 54	19 - 24
Slipring Bodies, High Voltage, Enclosed, Protection Class IP 54	25
Slipring Bodies, Ex and Gastight	26 - 29
Slipring Bodies for Welding or for Measuring Circuits	30
Components for Sliprings, Brushholders, Insulation Material	31 - 32
Questionnaire for Slipring Bodies	33 - 34
Technical Explanatory Notes	35 - 37
Conditions of Sale and Delivery	38 - 39



Slipring Bodies

Open or Enclosed Units,
for Electronic Data Transmission or Ex and Gastight Design

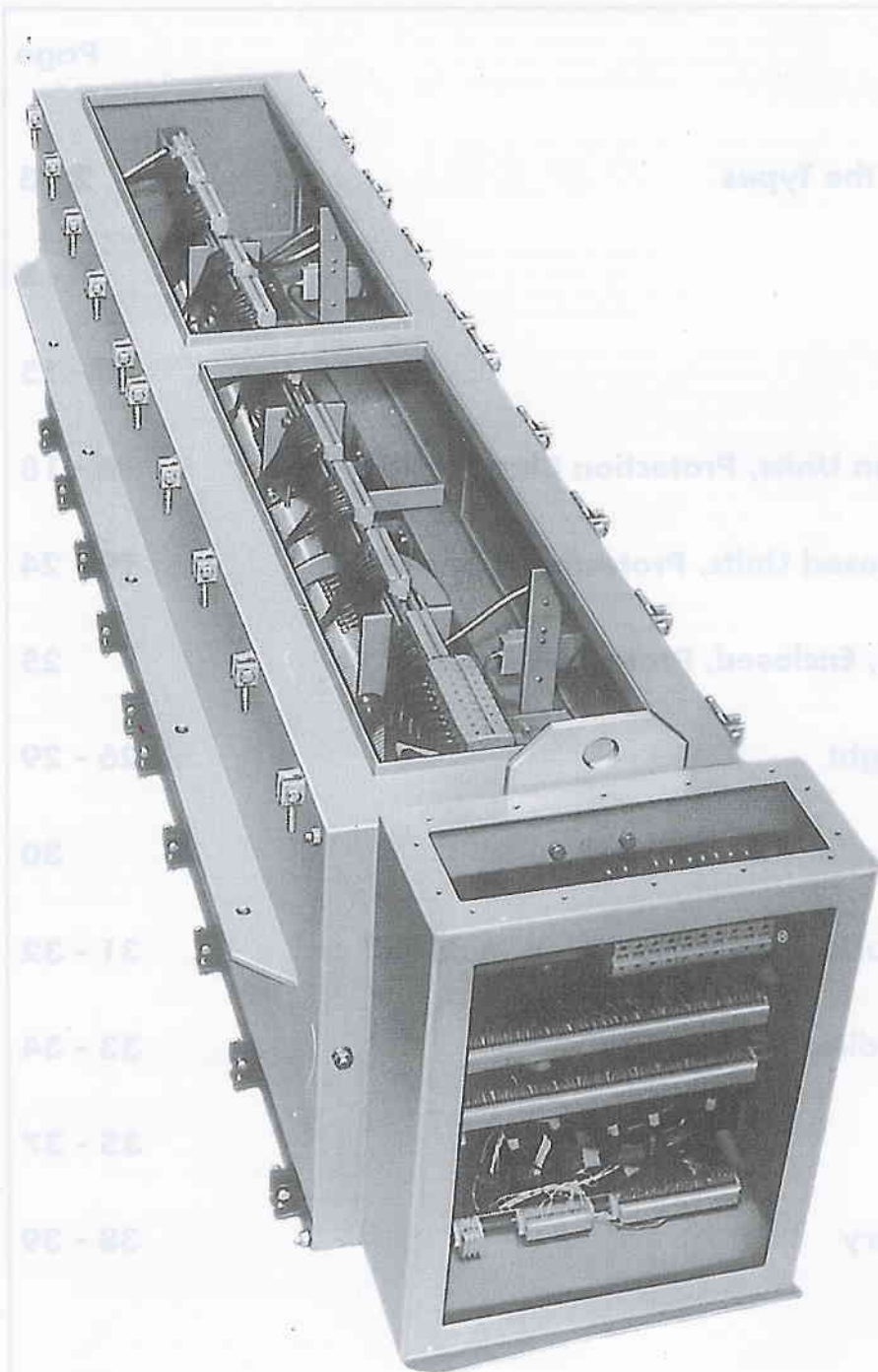

Slipring bodies are used to transmit electric current from a stationary supply point to rotating units. They are used on slewing cranes, turntables, rotary machinery, drill rigs, cable reeling drums, machine tools, etc.

Sliprings are either made solid or split and are arranged (flat) on top of each other.

We make sliprings to suit the application for an operating voltage of up to 30 000 Volts. The current capacities indicated are rated values. Please submit your enquiries should a higher current capacity be transmitted than that indicated.

Electric insulation is reached through special insulating materials which have a higher electrical, mechanical and thermic strength.

We make a large range of different types of slipring bodies. We supply high voltage, control line and low voltage slipring bodies which are available in gastight and ex flameproof design. On request we can also design units to conform to the ship's register specification.

The slipring bodies listed in this catalogue show only a part of our complete range. We also supply slipring bodies for nuclear power stations, drill platforms, underground mining and for general machinery. Should you fail to find a suitable unit in our catalogue, please do not hesitate to submit your enquiry together with full details including information on existing space and the use of the unit.

In order to make you an offer, we require the information from the questionnaire on pages 33 and 34.



Slipring Bodies

Summary of the Types

All the following slipring bodies with brushholders in open design (e.g. IP 00) or enclosed slipring units (e.g. IP 54) can be wired on request at an extra charge.

Sliprings:

- a) With leads 1,5 m long, measured from flange with PVC protection hose and Pg. gland.
- b) With terminals in the slipring housing. Sliprings wired.
- c) With an additionally separately enclosed terminal box and built-in terminals as well as leads with a PVC protection hose, 1,5 m long wired to the sliprings.

Brushholders:

- a) With leads 1,5 m long, measured from brushholder with PVC protection hose and Pg. gland.
- b) With terminals on the brushholders, brushholders wired.
- c) With an additionally separately enclosed terminal box and built-in terminals as well as leads with a PVC protection hose, 1,5 m long wired to the brushes.

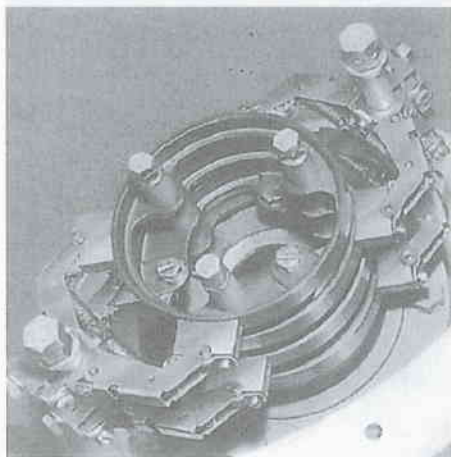

Summary of Types

Slipring Bodies		Pages	Rated current Amp.											
Type	Description		10	26	32	36	40	42	60	150	220	265	500	1000
	Operating voltage	V	230	500	230	500	500	500	500	500	500	500	500	500
YB	Block type	4	X	X	X	X	X	X	X	X	X			
YL	Air gap type	9		X	X	X	X	X	X	X	X	X	X	X
YLA	Air gap type, Ø 110 clearance	15				X	X	X						
YLC	Air gap type, Ø 180 clearance	15								X	X	X	X	X
YLT	Air gap type, split rings	15						K	K	K	K			
YLB	Air gap type, blocked type	14	X	X	X	X	X	X	X	X	X	X	X	X
YU	Rotating with bearings	16	X	X	X	X	X	X	X	X	X	X	X	X
YUD	Rotating with bearings, with spur	18	X	X	X	X	X	X	X	X	X	X	X	X
YK	Rotating with bearings, enclosed design IP 54	19	X	X	X	X	X	X	X	X	X	X	X	X
YKD	Rotating with bearings, enclosed design IP 54	24			X	X		X	X	X	X	X	X	X
YKH	High voltage, enclosed	25	on request											
YKE	Rotating with bearings, pressure closed, Sch/d-Ex/d	26			X	X		X	X	X	X	X	X	X
YSW	Current transmission, single pole, 400-2000 A	30											X	X
YSK	Rotating with bearings, for measuring currents	30	X											
	Slipring bodies, components	31	X	X	X	X	X	X	X	X	X	X	X	X
	Single brushholders	31	X	X	X	X	X	X	X	X	X	X	X	X
	Insulation material	32	X	X	X	X	X	X	X	X	X	X	X	X

K = Terminal Holder
X = Oscillating Brushholder



Slipring Bodies

Type YB, 10 A, Block Type with Wire Brushholders, Protection Class IP 00

Type YB, 10 A

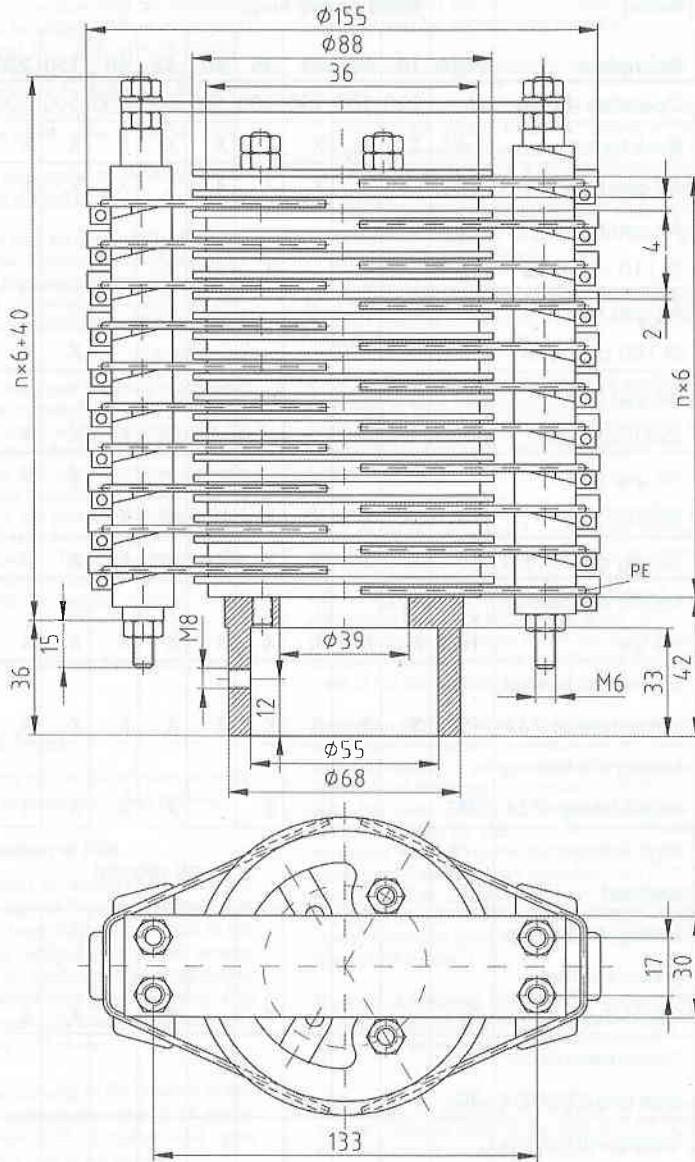

Type YB, 10 A¹⁾

Technical Data

Operating voltage up to 230 V (3~) or 280 V= . Contact resistance $\leq 12 \text{ m}\Omega$

Brass sliprings, not split, with screw connection M 4.

Wire brushholders, surface treated

Connection for 2,5 mm².

Insulating discs made out of special plastic.

Insulation by hard fibre tubing and plastic supports.

Design

11 + earth 10 A at S1 (100% duty cycle) specially for control cables.

This design can be made up to 70 poles for 1,5 mm² connection.

n = number of poles

Caution

This slipring body with wire brushholders can only be used for max. = 30 min⁻¹.

Contact grease should be rubbed on after 100 000 rotations.

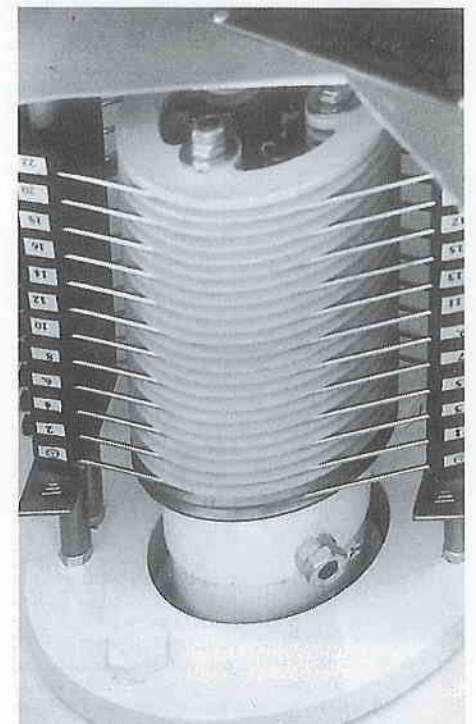

¹⁾ Dimensions unbinding



Slipring Bodies

Type YB, 36 A and YB, 40 A, Block Type, with Oscillating Brushholders, Protection Class IP 00

Type YB, 36 A

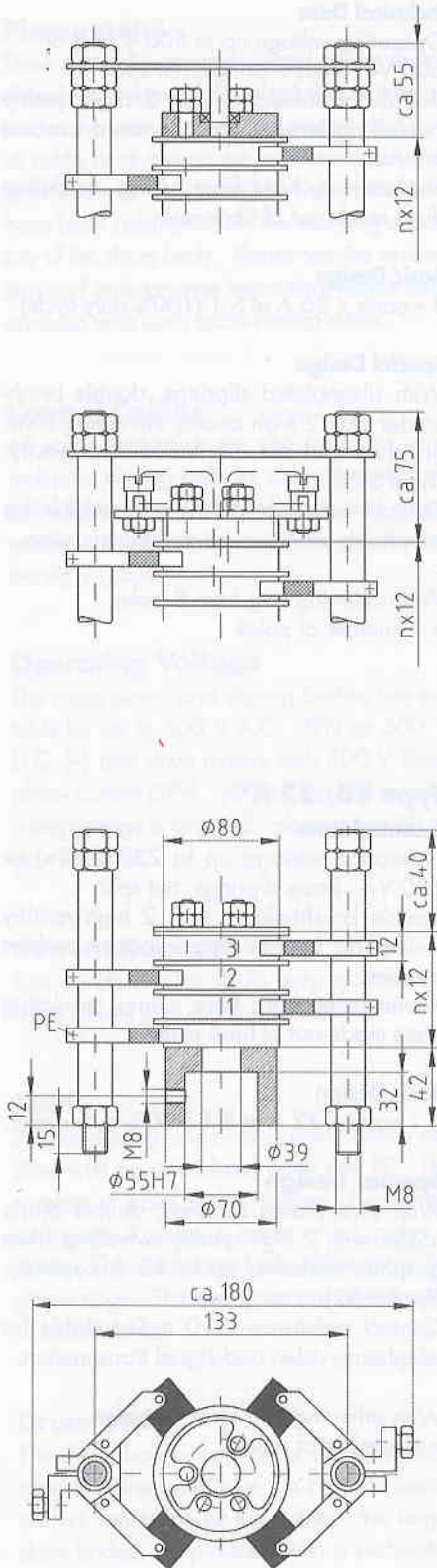

Type YB, 40 A

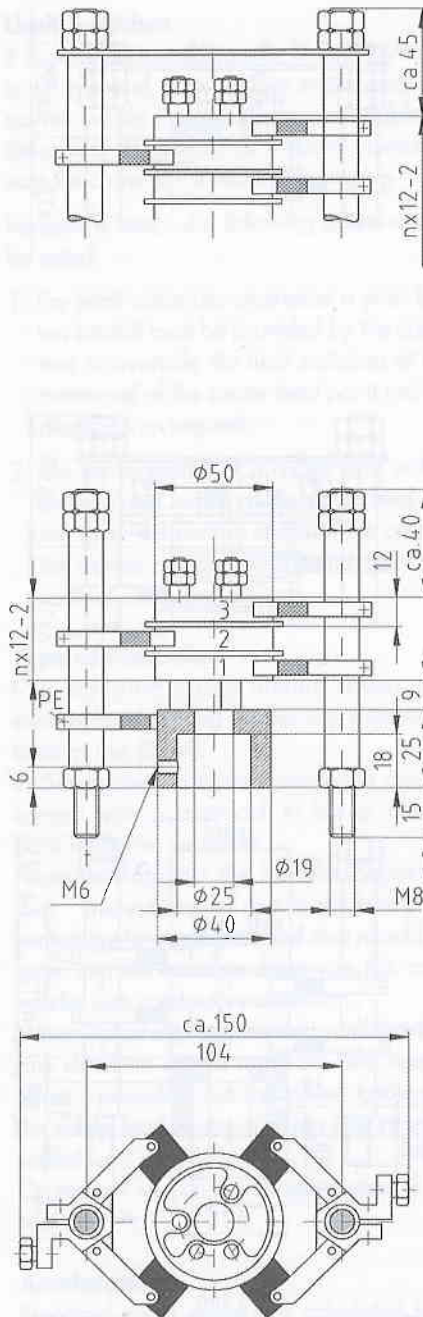

Type YB, 36 A¹⁾

Technical Data

Operating voltage up to 500 V (3~) or 600 V=. Brass sliprings, not split. Double brushholders with 2 high quality swivelling bronze impregnated carbon brushes. Insulation by hard fibre tubing. Insulating discs made out of fibre resin.

Basic Design

3+earth / 36 A at S 1 (100% duty cycle).

Special Design

With silver-plated sliprings, double brushholder with 2 high quality swivelling silver graphite carbons, up to 36 A capacity. (Type S 36).

Contact resistance $\leq 10 \text{ m}\Omega$ suitable for telephone, video and signal transmission.

With stiffening ring from 8 poles
n = number of poles

Type YB, 40 A¹⁾

Technical Data

Operating voltage up to 500 V (3~) or 600 V=. Brass sliprings, not split. Double brushholders with 2 high quality swivelling bronze impregnated carbon brushes. Insulation by hard fibre tubing. Insulating discs made out of fibre resin.

Basic Design

3+earth / 40 A at S1 (100% duty cycle).

With stiffening ring from 8 poles
n = number of poles

¹⁾ Dimensions unbinding



Slipring Bodies

Type YB, 42 A and YB, 60 A, Block Type, with Oscillating Brushholders, Protection Class IP 00

Type YB, 42 A

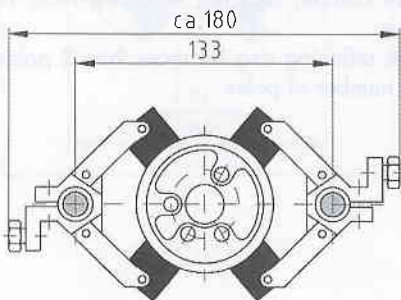
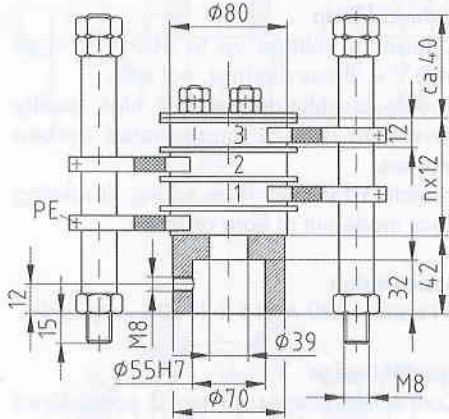
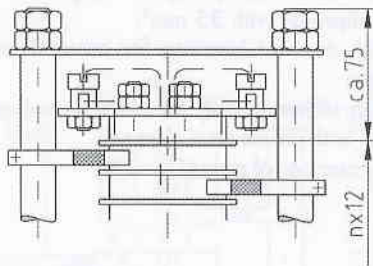
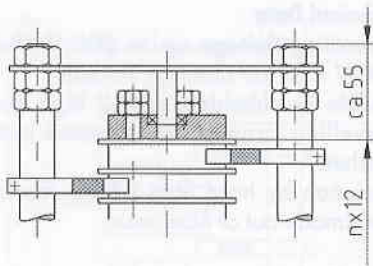

Type YB, 60 A

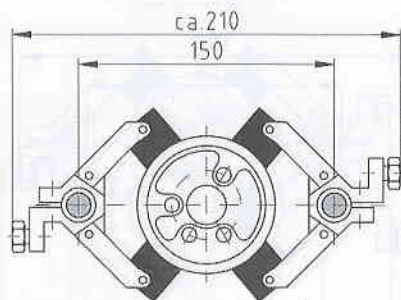
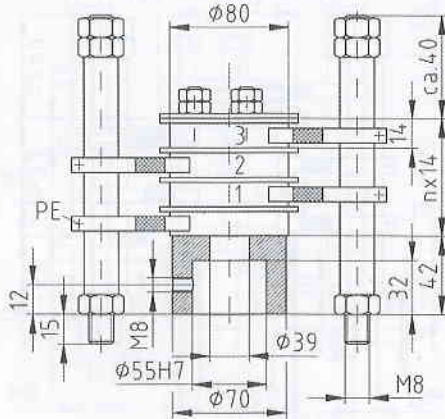
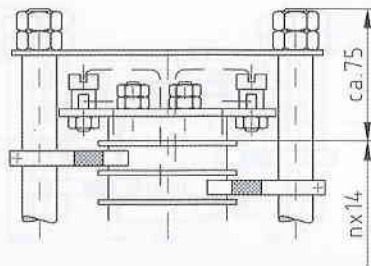
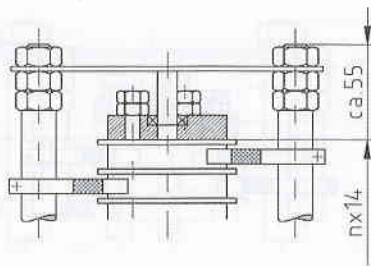

Type YB, 42 A¹⁾

Technical Data

Operating voltage up to 500 V (3~) or 600 V=. Brass sliprings, not split. Double brushholders with 2 high quality swivelling bronze impregnated carbon brushes. Insulation by hard fibre tubing. Insulating discs made out of fibre resin.

Basic Design

3+earth / 42 A at S 1 (100% duty cycle).

Special Design

Connection clamps up to 16 poles wired on sliprings with 2,5 mm².

With counter bearing from 23 poles
With stiffening ring from 8 poles and connection clamps.
n = number of poles

Type YB, 60 A¹⁾

Technical Data

Operating voltage up to 500 V (3~) or 600 V=. Brass sliprings, not split. Double brushholders with 2 high quality swivelling bronze impregnated carbon brushes. Insulation by hard fibre tubing. Insulating discs made out of fibre resin.

Basic Design

3+earth / 60 A at S 1 (100% duty cycle).

Special Design

Connection clamps up to 12 poles wired on sliprings with 4 mm² and 9 poles wired on sliprings with 10 mm².

With counter bearing from 16 poles
With stiffening ring from 6 poles and connection clamps.
n = number of poles

¹⁾ Dimensions unbinding



Slipring Bodies

Type YB, 150 A and YB, 220 A, Block Type, with Oscillating Brushholders, Protection Class IP 00

Type YB, 150 A

Type YB, 220 A

Type YB, 150 A¹⁾

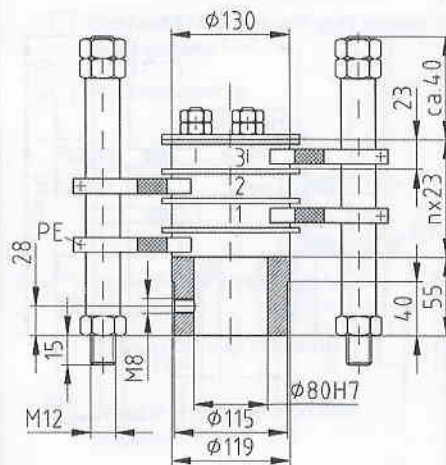
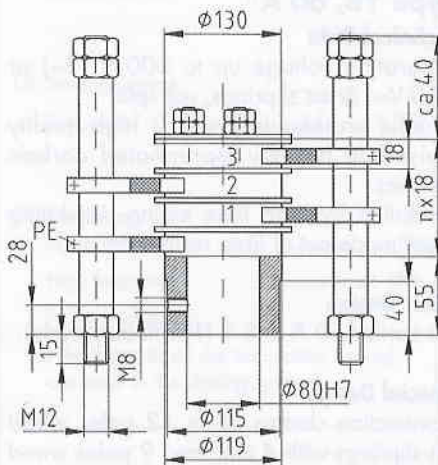
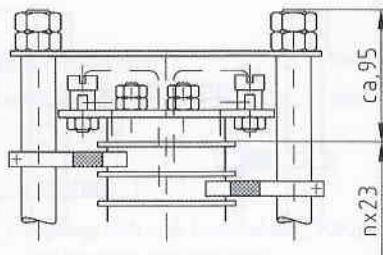
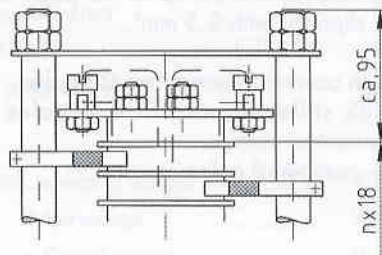
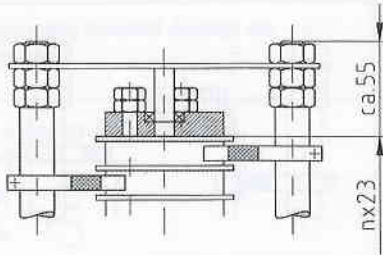
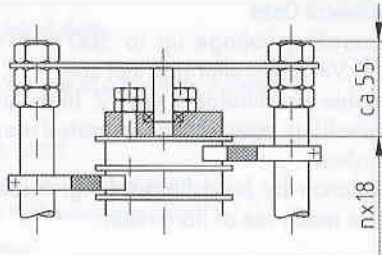

Technical Data

Operating voltage up to 500 V (3~) or 600 V =. Brass sliprings, not split. Double brushholders with 2 high quality swivelling bronze impregnated carbon brushes. Insulation by hard fibre tubing. Insulating discs made out of fibre resin.

Basic Design

3+earth / 150 A at S1 (100% duty cycle).

Special Design

Connection clamps up to 16 poles wired on sliprings with 35 mm². With counter bearing for more than 11 poles. With stiffening ring for more than 6 poles and with connection clamps. n = number of poles

Type YB, 220 A¹⁾

Technical Data

Operating voltage up to 500 V (3~) or 600 V =. Brass sliprings, not split. Double brushholders with 2 high quality swivelling bronze impregnated carbon brushes. Insulation by hard fibre tubing. Insulating discs made out of fibre resin.

Basic Design

3+earth / 220 A at S1 (100% duty cycle).

Special Design

Connection clamps up to 12 poles wired on sliprings with 70 mm². With counter bearing for more than 10 poles. With stiffening ring for more than 2 poles. n = number of poles

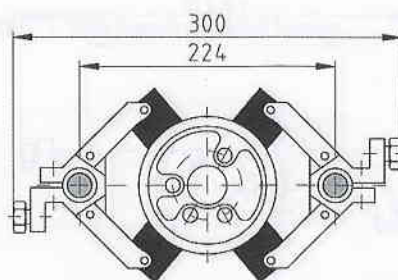
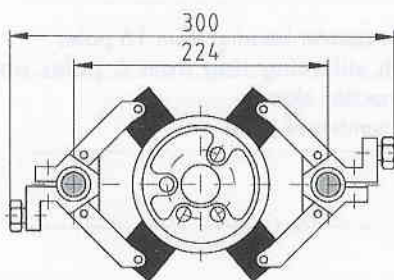

¹⁾ Dimensions unbinding



Slipring Bodies

Type YL, 26 A and YL, 32 A, Air Gap Type, with Oscillating Brushholders, Protection Class IP 00

Type YL, 26 A

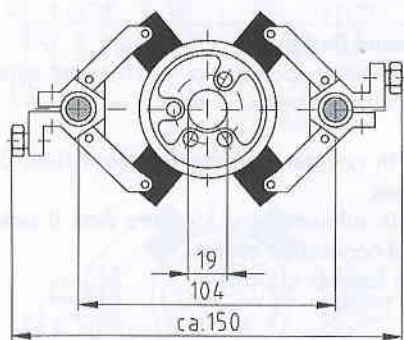
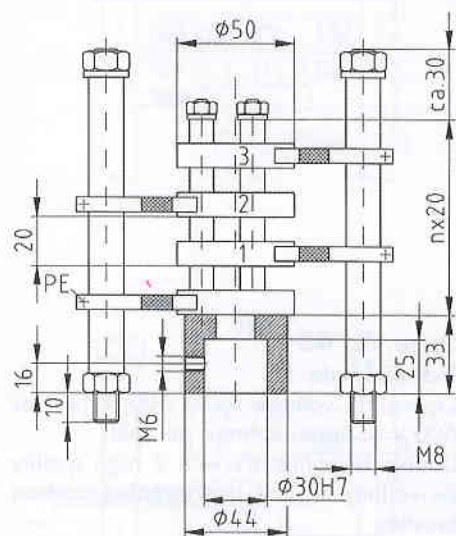
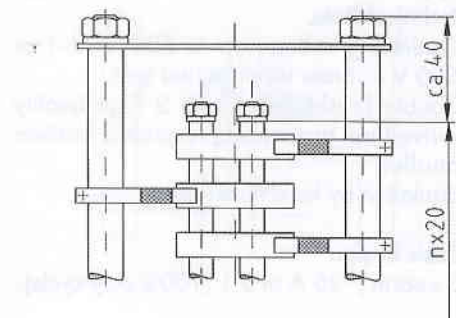

Type YL, 32 A

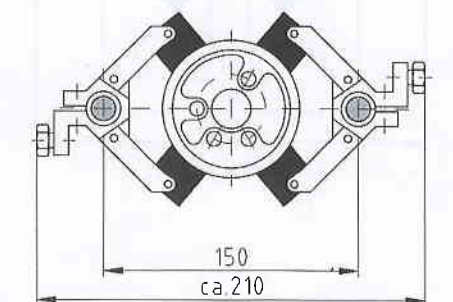
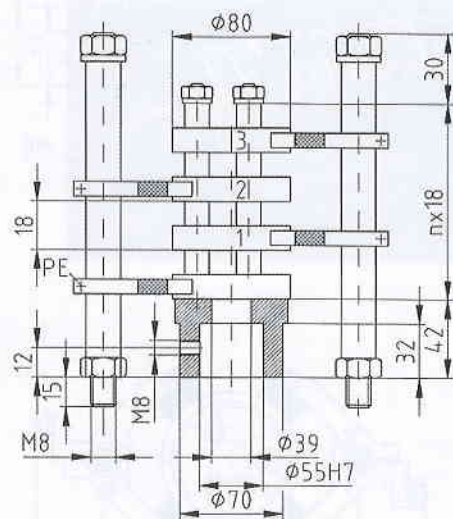
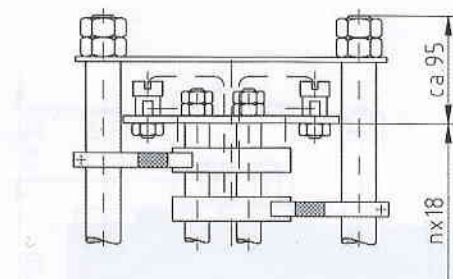
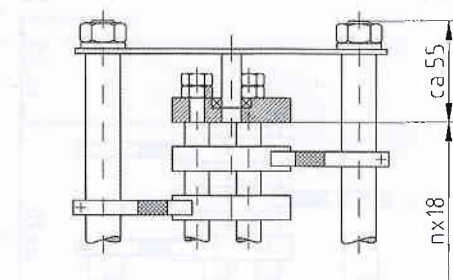

Type YL, 26 A¹⁾

Technical Data

Operating voltage up to 500 V (3~) or 600 V =. Brass sliprings, not split. Double brushholders with 2 high quality swivelling bronze impregnated carbon brushes. Insulation by hard fibre tubing.

Basic Design

3+earth / 26 A at S 1 (100% duty cycle).

Special Design

With silver-plated sliprings, double brushholder with 2 high quality swivelling silver graphite carbons, up to 26 A capacity. (Type S 26). Contact resistance $\leq 10 \text{ m}\Omega$ suitable for telephone, video and signal transmission.

With stiffening ring for more than 6 poles.
n = number of poles

Type YL, 32 A¹⁾

Technical Data

Operating voltage up to 500 V (3~) or 600 V =. Brass sliprings, not split. Double brushholders with 2 high quality swivelling bronze impregnated carbon brushes. Insulation by hard fibre tubing.

Basic Design

3+earth / 32 A at S 1 (100% duty cycle).

Special Design

- Terminals up to 16 poles wired on sliprings with $2,5 \text{ mm}^2$.
- With silver-plated sliprings, double brushholder with 2 high quality swivelling silver graphite carbons, up to 32 A capacity. (Type S 32). Contact resistance $\leq 10 \text{ m}\Omega$ suitable for telephone, video and signal transmission.

With counter bearing for more than 23 poles.

With stiffening ring for more than 8 poles and connection clamps.
n = number of poles

¹⁾ Dimensions unbinding



Slipring Bodies

Type YL, 36 A and YL, 40 A, Air Gap Type, with Oscillating Brushholders, Protection Class IP 00

Type YL, 36 A

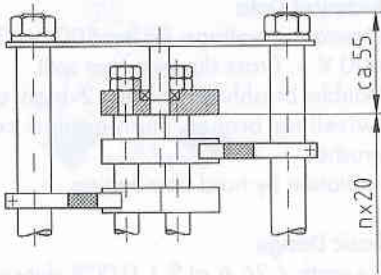

Type YL, 40 A

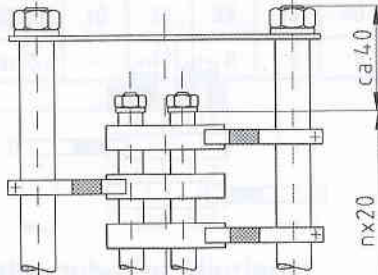

Type YL, 36 A¹⁾

Technical Data

Operating voltage up to 500 V (3~) or 600 V =. Brass sliprings, not split. Double brushholders with 2 high quality swivelling bronze impregnated carbon brushes. Insulation by hard fibre tubing.

Basic Design

3+earth / 36 A at S 1 (100% duty cycle).

With stiffening ring for more than 6 poles.
n = number of poles

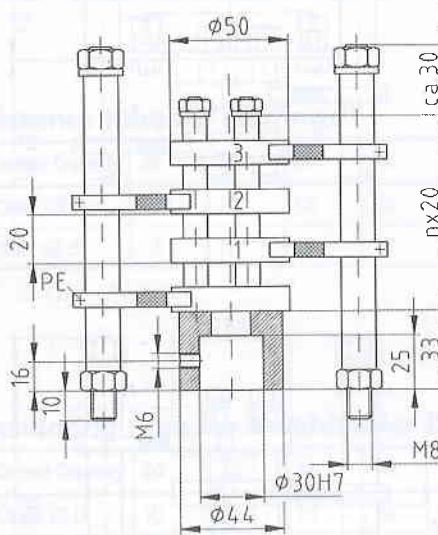
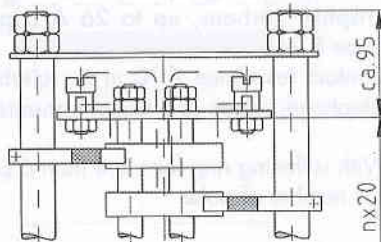

Type YL, 40 A¹⁾

Technical Data

Operating voltage up to 500 V (3~) or 600 V =. Brass sliprings, not split. Double brushholders with 2 high quality swivelling bronze impregnated carbon brushes. Insulation by hard fibre tubing.

Basic Design

3+earth / 40 A at S 1 (100% duty cycle).

Special Design

Connection clamps up to 16 poles wired on sliprings with 2,5 mm².

With counter bearing for more than 23 poles.

With stiffening ring for more than 8 poles and connection clamps.

n = number of poles

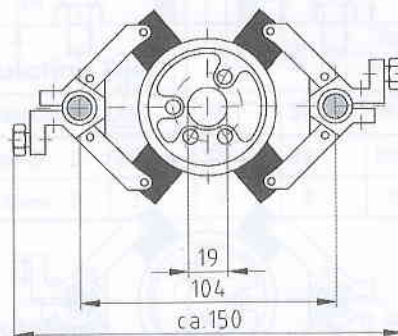
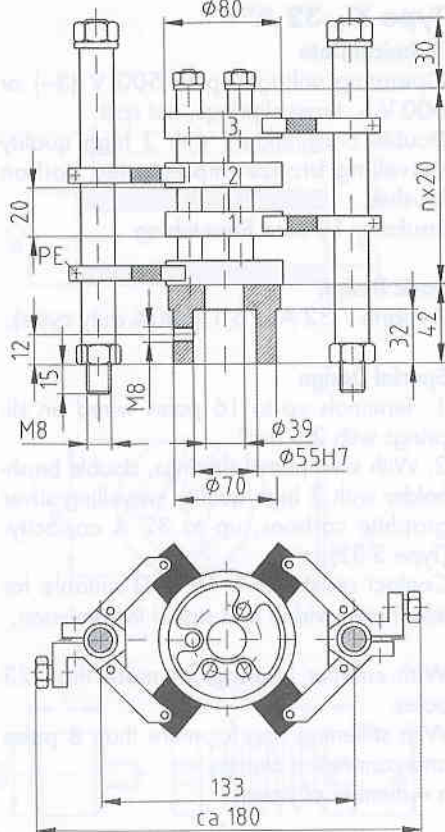

¹⁾ Dimensions unbinding



Slipring Bodies

Type YL, 42 A, Air Gap Type, with Oscillating Brushholders,
Protection Class IP 00

Type YL, 42 A

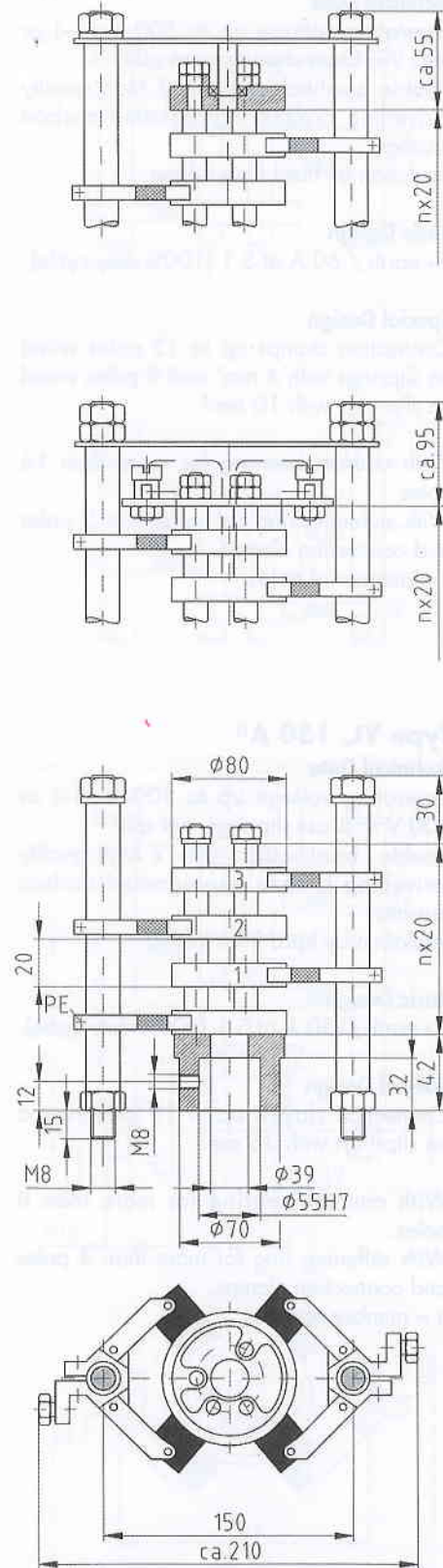

Type YL, 42 A¹⁾

Technical Data

Operating voltage up to 500 V (3~) or 600 V =. Brass sliprings, not split.
Double brushholders with 2 high quality swivelling bronze impregnated carbon brushes.
Insulation by hard fibre tubing.

Basic Design

3+earth / 42 A at S 1 (100% duty cycle).

Special Design

Terminals up to 16 poles wired on sliprings with 2,5 mm².

With counter bearing for more than 23 poles.

With stiffening ring for more than 8 poles and connection clamps.

n = number of poles

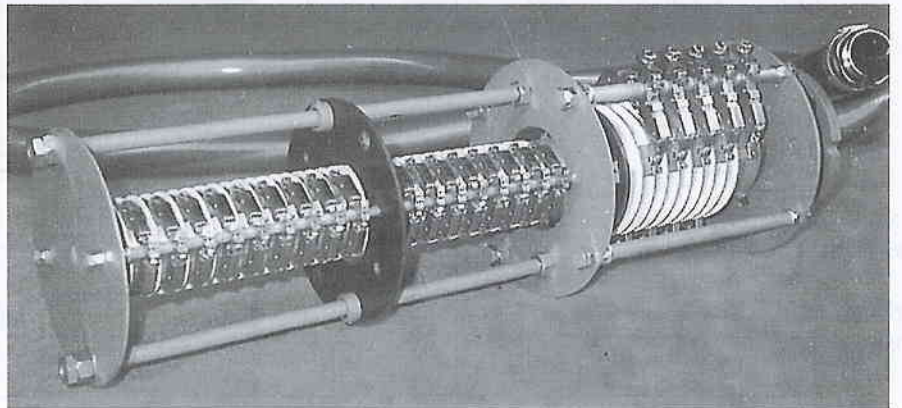

¹⁾ Dimensions unbinding



Slipring Bodies

Type YL, 60 A and YL, 150 A, Air Gap Type, with Oscillating Brushholders, Protection Class IP 00

Type YL, 60 A

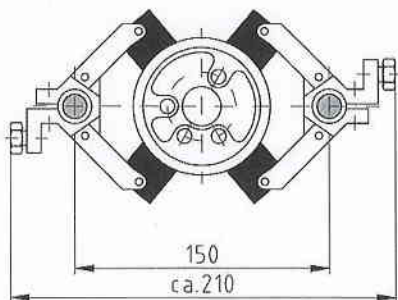
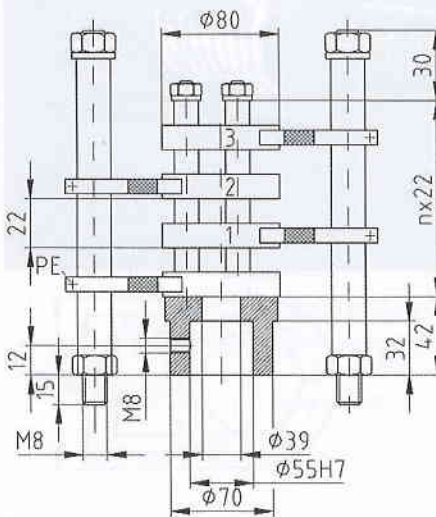
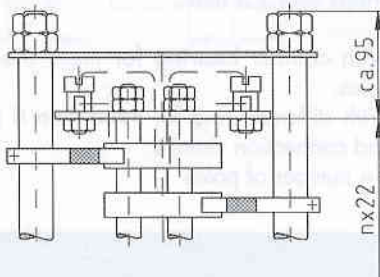
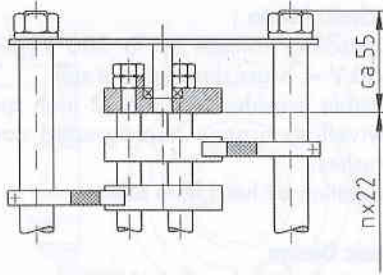

Type YL, 150 A

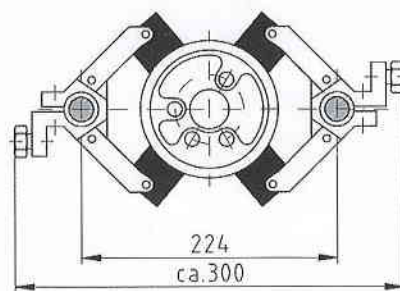
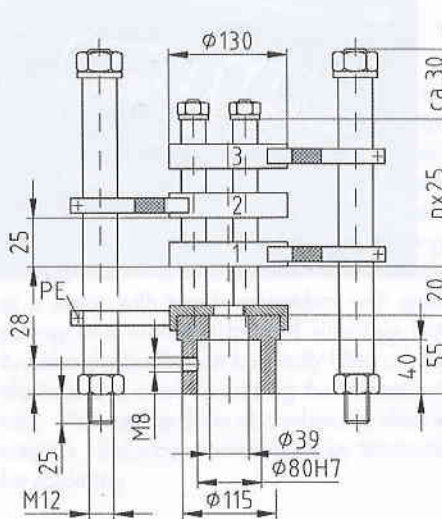
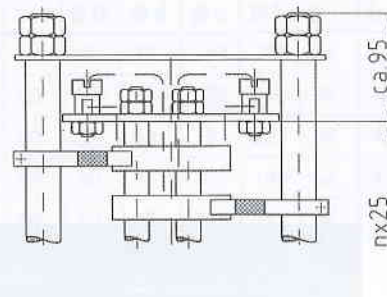
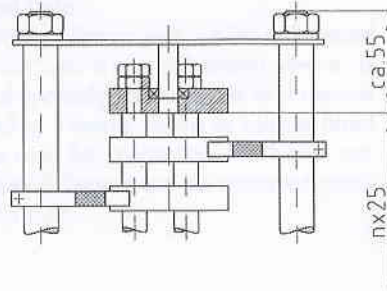

Type YL, 60 A¹⁾

Technical Data

Operating voltage up to 500 V (3~) or 600 V=. Brass sliprings, not split. Double brushholders with 2 high quality swivelling bronze impregnated carbon brushes. Insulation by hard fibre tubing.

Basic Design

3+earth / 60 A at S 1 (100% duty cycle).

Special Design

Connection clamps up to 12 poles wired on sliprings with 4 mm² and 9 poles wired on sliprings with 10 mm².

With counter bearing for more than 16 poles

With stiffening ring for more than 5 poles and connection clamps.

n = number of poles

Type YL, 150 A¹⁾

Technical Data

Operating voltage up to 500 V (3~) or 600 V=. Brass sliprings, not split. Double brushholders with 2 high quality swivelling bronze impregnated carbon brushes. Insulation by hard fibre tubing.

Basic Design

3+earth / 150 A at S 1 (100% duty cycle).

Special Design

Connection clamps up to 16 poles wired on sliprings with 35 mm².

With counter bearing for more than 8 poles.

With stiffening ring for more than 4 poles and connection clamps.

n = number of poles

¹⁾ Dimensions unbinding



Slipring Bodies

Type YL, 220 A and YL, 265 A, Air Gap Type, with Oscillating Brushholders, Protection Class IP 00

Type YL, 220 A

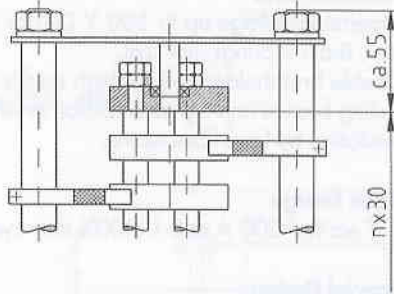

Type YL, 265 A

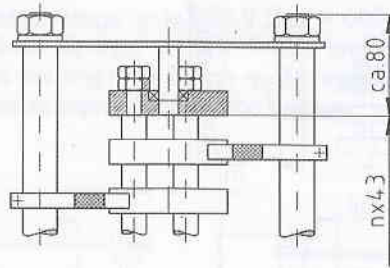

Type YL, 220 A¹⁾

Technical Data

Operating voltage up to 500 V (3~) or 600 V=. Brass sliprings, not split. Double brushholders with 2 high quality swivelling bronze impregnated carbon brushes. Insulation by hard fibre tubing.

Basic Design

3 + earth / 220 A at S 1 (100% duty cycle).

Special Design

1. Connection clamps up to 12 poles wired on sliprings with 70 mm².
2. With counter bearing for more than 6 poles.

With stiffening ring for more than 2 poles and connection clamps.
n = number of poles

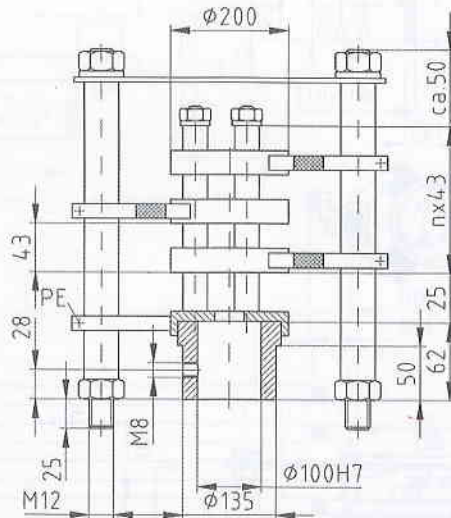
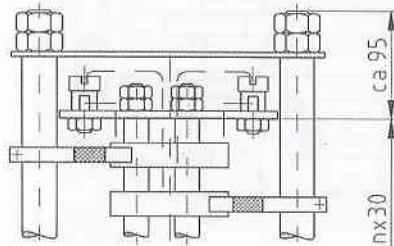

Type YL, 265 A¹⁾

Technical Data

Operating voltage up to 500 V (3~) or 600 V=. Brass sliprings, not split. Double brushholders with 2 high quality swivelling bronze impregnated carbon brushes. Insulation by hard fibre tubing.

Basic Design

3+earth/265 A at S 1 (100% duty cycle).

Special Design

- With counter bearing for more than 5 poles.
- With stiffening ring.

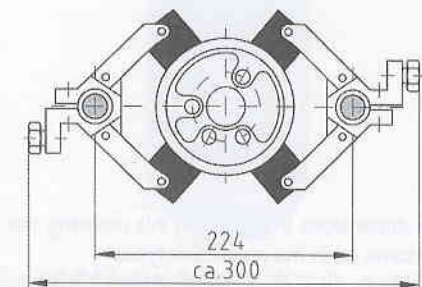
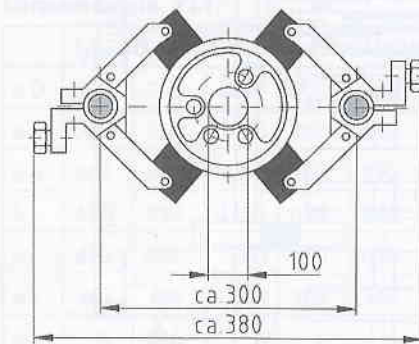
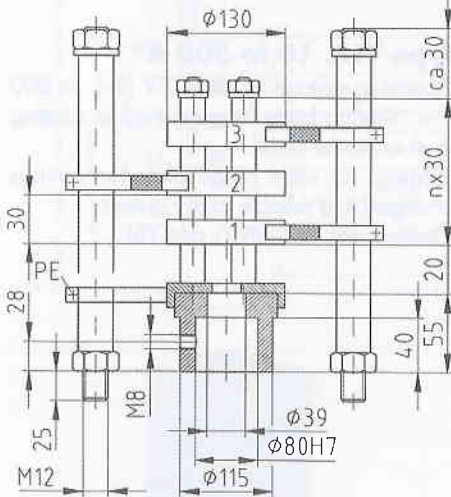

¹⁾ Dimensions unbinding



Slipring Bodies

Type YL, 500 A and YLB, 10 to 500 A, Air Gap Type, with Oscillating Brushholders, Protection Class IP 00

Type YL, 500 A

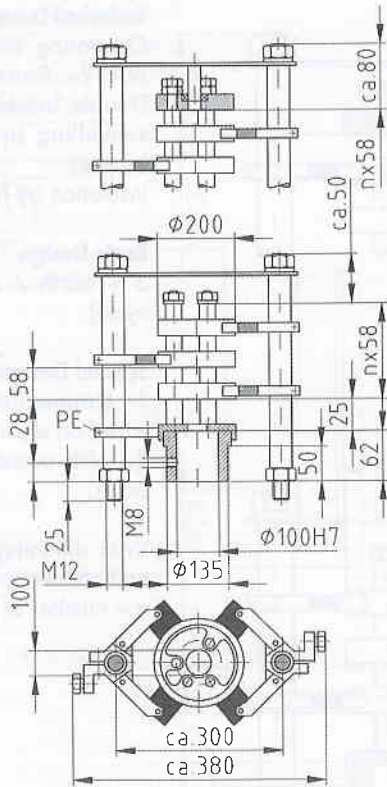

Type YL, 500 A¹⁾

Technical Data

Operating voltage up to 500 V (3~) or 600 V =. Brass sliprings, not split. Double brushholders with 2 high quality swivelling bronze impregnated carbon brushes. Insulation by hard fibre tubing.

Basic Design

3 + earth / 500 A at S 1 (100% duty cycle).

Special Design

With counter bearing for more than 5 poles. With stiffening ring.

Type YLB, 10 to 500 A

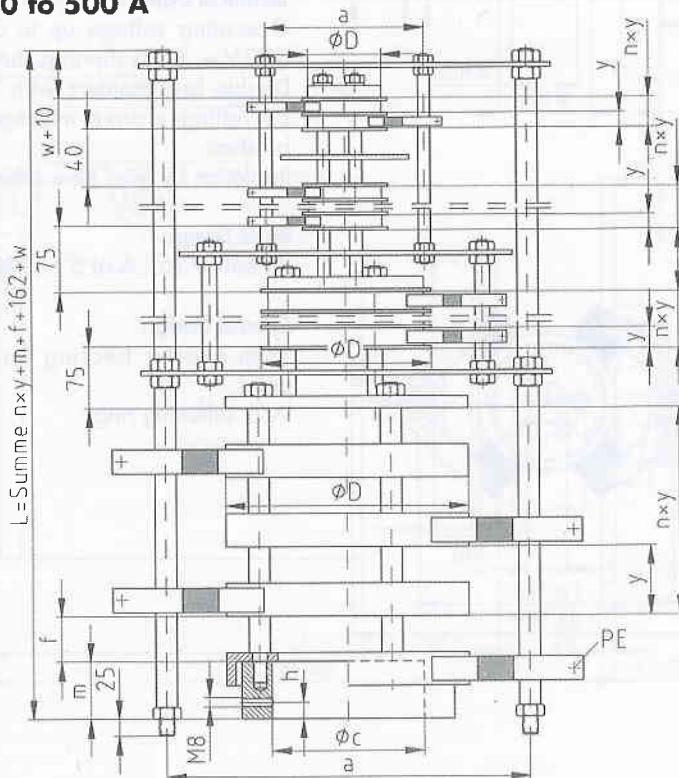

Type YLB, 10 to 500 A¹⁾

Operating voltage up to 500 V (3~) or 600 V =. Slipring body for mounting on rotating shaft or similar base.

Sliprings for wide range of current ratings arranged in a reliable rotary system. (Designs acc. to types YL and YB).

The dimensions indicated in this drawing are the same as in the respective types YL 500 A, YB 220 A, YB 60 A and YB 32 A.

¹⁾ Dimensions unbinding



Slipring Bodies

Type YLA, 26 to 60 A, Type YLC, 150 to 1000 A, Type YLT, 42 to 220 A, Air Gap Type, with Oscillating Brushholders or Tangential Brushholders, Protection Class IP 00

Type YLA und YLC

Technical Data

Operating voltage up to 500 V (3~) or 600 V =. Brass sliprings, not split. Double brushholders per ring with 2 high quality swivelling bronze impregnated carbon brushes.

For 1000 A capacity there are 4 carbon brushes per ring. Insulation by hard fibre tubing and resin insulators.

Type YLA and YLC

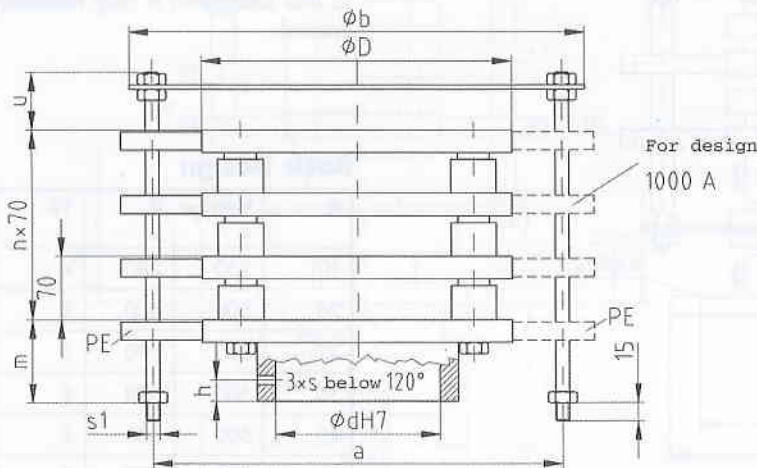

Dimensions YLA YLC¹⁾

	Type YLA	Type YLC				
	Current Rating A	Current Rating A				
	26-60	150	220	265	500	1000
d	110	180	180	180	180	180
a	260	450	450	450	460	460
b	300	500	500	500	520	520
D	200	340	340	340	340	340
h	20	25	25	25	25	25
m	60	90	90	90	90	90
s	M8	M10	M10	M10	M10	M10
s	M8	M12	M12	M12	M12	M12
u	40	70	70	70	70	70
x	25	70	70	70	70	70

Type YLT

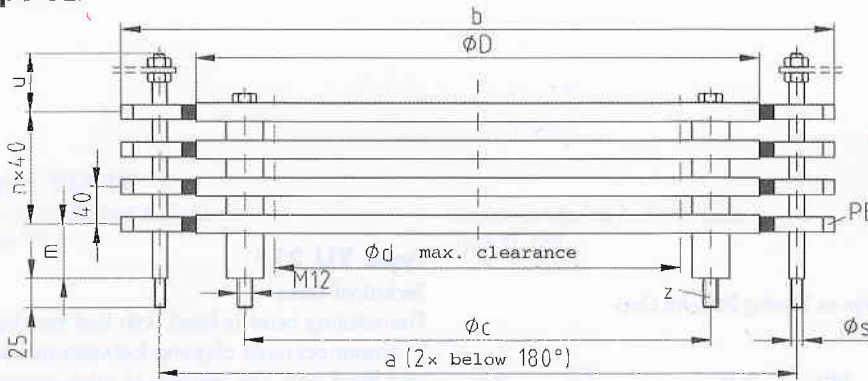

Type YLT¹⁾

Technical Data

Operating voltage up to 500 V (3~) or 600 V =. Brass sliprings split.

Double brushholders per ring with 2 - 4 high quality swivelling brushholders and bronze impregnated carbon brushes.

Dimensions YLT¹⁾

	Type YLT 42 (42 A)			Type YLT 60 (60 A)			Type YLT 150 (150 A)			Type YLT 220 (220 A)		
	ϕD	ϕd	ϕa	ϕD	ϕd	ϕa	ϕD	ϕd	ϕa	ϕD	ϕd	ϕa
ϕD	500	750	1000	500	750	1000	500	750	1000	500	750	1000
ϕd	360	550	800	360	550	800	360	550	800	300	550	800
ϕa	560	810	1060	560	810	1060	560	830	1080	580	830	1080
b	630	880	1120	630	880	1120	680	930	1160	680	930	1160
ϕc	420	650	900	420	650	900	420	650	900	400	650	900
ϕs	M8	M8	M8	M8	M8	M8	M8	M12	M12	M12	M12	M12
z	4	6	8	4	6	8	4	6	8	4	6	8
m	50	55	55	50	55	55	50	55	55	55	55	55
u	50	55	55	50	55	55	50	55	55	60	60	60
x	43	40	40	43	40	40	43	40	40	45	45	45

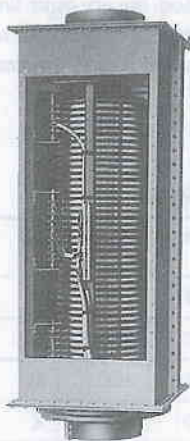

Enclosed Slipring Body IP 54

¹⁾ Dimensions unbinding



Slipring Bodies

Rotating with Bearings, Protection Class IP 00,
Type YU 16 and YU 21 with Oscillating Brushholders

Type YU 16

Design as Slipring Body-Block
Type YB

Design as Slipring Body-Air Gap
Type YL

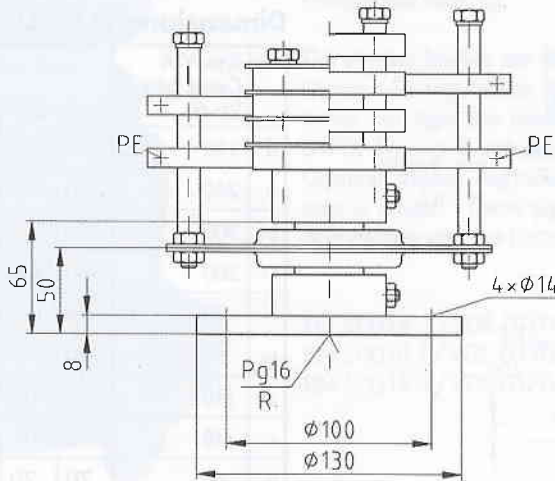

Type YU 16¹⁾

Technical Data

The rotating base is fitted with ball bearings to ensure accurate aligning between rotating and fixed part. The unit should rotate smoothly - there should be no rigid link. Ball bearings are sealed and greased at our works so that lubrication is only necessary at long intervals.

Basic Design

A	Voltage V		YB	YL
	~	=		
10	230	280	X	
26	500	600	X	X
32	230	280	X	
36	500	600	X	X
40	500	600	X	X
42	500	600	X	X

Type YU 21

Design as Slipring Body-Block
Type YB

Design as Slipring Body-Air Gap
Type YL

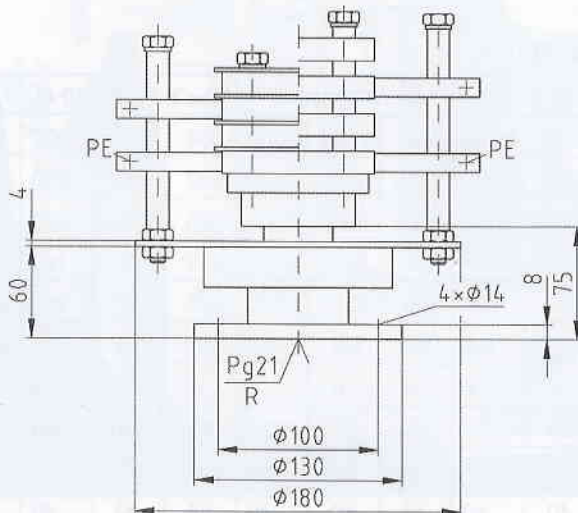

Type YU 21¹⁾

Technical Data

The rotating base is fitted with ball bearings to ensure accurate aligning between rotating and fixed part. The unit should rotate smoothly - there should be no rigid link. Ball bearings are sealed and greased at our works so that lubrication is only necessary at long intervals.

Basic Design

A	Voltage V		YB	YL
	~	=		
10	230	280	X	
32	230	280	X	X
36	500	600	X	X
42	500	600	X	X
60	500	600	X	

¹⁾ Dimensions unbinding



Slipring Bodies

Rotating with Bearings, Protection Class IP 00,
Type YU 36 and YU 48 with Oscillating Brushholders

Type YU 36

Design as Slipring Body-Block
Type YB

Design as Slipring Body-Air Gap
Type YL

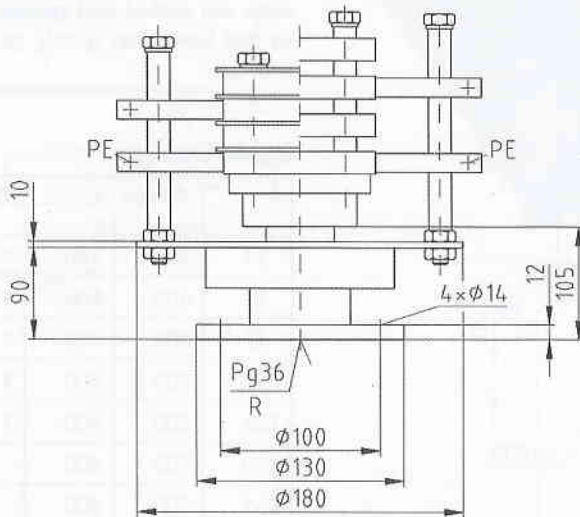

Type YU 36¹⁾

Technical Data

The rotating base is fitted with ball bearings to ensure accurate aligning between rotating and fixed part. The unit should rotate smoothly - there should be no rigid link. Ball bearings are sealed and greased at our works so that lubrication is only necessary at long intervals.

Basic Design

A	Voltage V		YB	YL
	~	=		
10	230	280	X	
32	230	280	X	
36	500	600	X	X
42	500	600	X	X
60	500	600	X	X
150	500	600	X	X

Type YU 48

Design as Slipring Body-Block
Type YB

Design as Slipring Body-Air Gap
Type YL 150

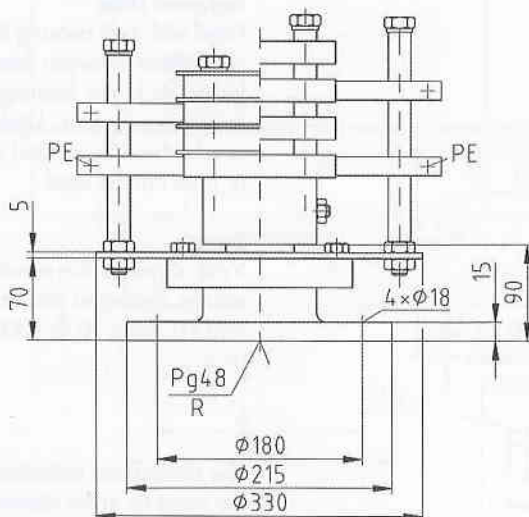

Type YU 48¹⁾

Technical Data

The rotating base is fitted with ball bearings to ensure accurate aligning between rotating and fixed part. The unit should rotate smoothly - there should be no rigid link. Ball bearings are sealed and greased at our works so that lubrication is only necessary at long intervals.

Basic Design

A	Voltage V		YB	YL
	~	=		
32	230	280	X	
36	500	600	X	X
42	500	600	X	X
60	500	600	X	X
150	500	600	X	X
220	500	600		X

¹⁾ Dimensions unbinding



Slipring Bodies

Rotating with Bearings, Protection Class IP 00,
Type YU 80 and YUD 135/150 with Oscillating Brushholders

Type YU 80

Design as Slipring Body-Air Gap
Type YL

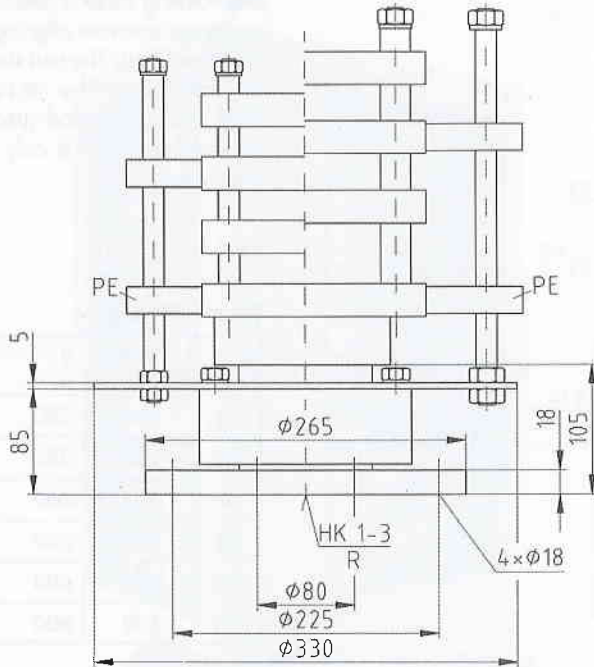

Type YU 80¹⁾

Technical Data

The rotating base is fitted with ball bearings to ensure accurate aligning between rotating and fixed part. The unit should rotate smoothly - there should be no rigid link. Ball bearings are sealed and greased at our works so that lubrication is only necessary at long intervals.

Basic Design

A	Voltage		YB	YL
	~	=		
32	230	280	X	
36	500	600	X	X
42	500	600	X	X
60	500	600	X	X
150	500	600	X	X
220	500	600		X
265	500	600		X
500	500	600		X

Type YUD

Design as Slipring Body-Block
Type YUD

Design as Slipring Body-Air Gap
Type YL

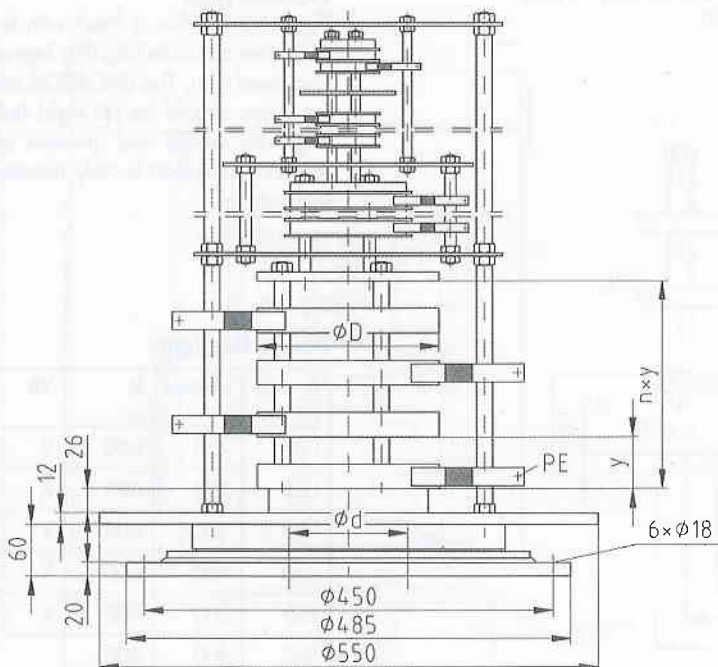

Types

Hole mm	Types YUD 135	YUD 150
Ø D	200	340
Ø d	135	150
x	58	70

Type YUD 135/150¹⁾

Technical Data

Fitted with ball bearing for accurate and firm connection between fixed and rotating unit (pillar etc.). The bearings can be lubricated by grease nipples. Under no circumstances should there be a rigid connection. A chain or rope can be used.

Design

With sliprings for a wide range of current ratings arranged acc. to types YB, YL, YLB and YLC from 10 to 1000 A.

The dimensions indicated in this drawing are the same as in the respective types YL 500 A, YB 60 A and YB 32 A.

¹⁾ Dimensions unbinding



Slipring Bodies

Rotating with Bearings, Protection Class IP 54,
Type YK 11 and YK 16 with Oscillating Brushholders

Type YK 11

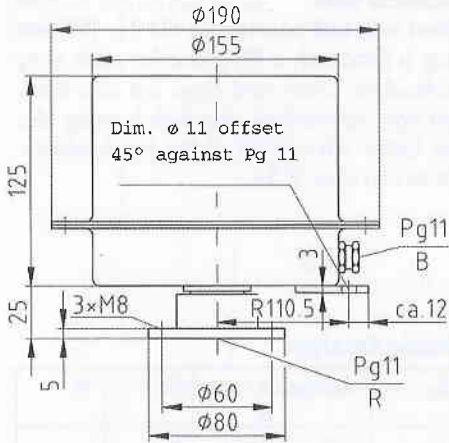

Type YK 11¹⁾

Technical Data

Fitted with ball bearings. The housing is fitted with a PG gland for cable entry to brushes. Chain and clasp are also fitted, (no rigid connection). The high housing allows better connection of the brushholders. Protection class IP 54.

Basic Design

A	Voltage V		YB
	~	=	
26	500	600	X
40	500	600	X

max. No. of Poles 6+PE

Type YK 16

Design as Slipring Body-Block
Type YB

Design as Slipring Body-Air Gap
Type YL

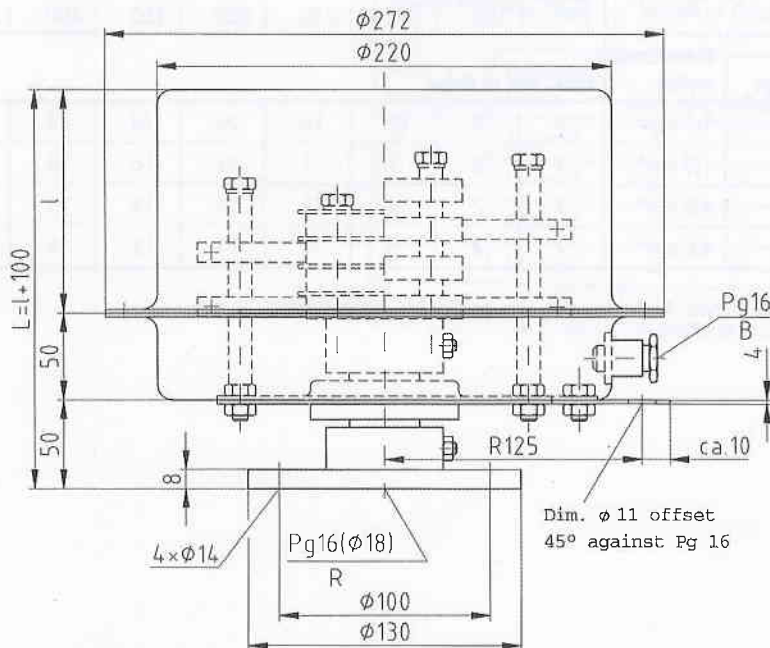

Type YK 16¹⁾

Technical Data

Fitted with ball bearings as for YU 16. The housing is fitted with a PG gland for cable entry to brushes. Chain and clasp are also fitted, (no rigid connection). The high housing allows better connection of the brushholders. Protection class IP 54.

Basic Design

A	Voltage V		YB	YL
	~	=		
10	230	280	X	
26	500	600	X	X
32	230	280	X	
36	500	600	X	X
40	500	600	X	X
42	500	600	X	X

Dimensions

Type of Housing YK16	Length of Gap l in mm	100 150 200 250			
		max. no. of poles			
YB	1,5 mm ²	4	8	12	16
YL	2,5 mm ²	3	6	8	11

Shaft clearance: Note no. of poles and cable cross-section

¹⁾ Dimensions unbinding
R = Cable entry to rings
B = Cable entry to brushholders



Slipring Bodies

Rotating with Bearings, Enclosed, Protection Class IP 54,
Type YK 21 with Oscillating Brushholders

Type YK 21

Design as Slipring Body-Block
Type YB

Design as Slipring Body-Air Gap
Type YL

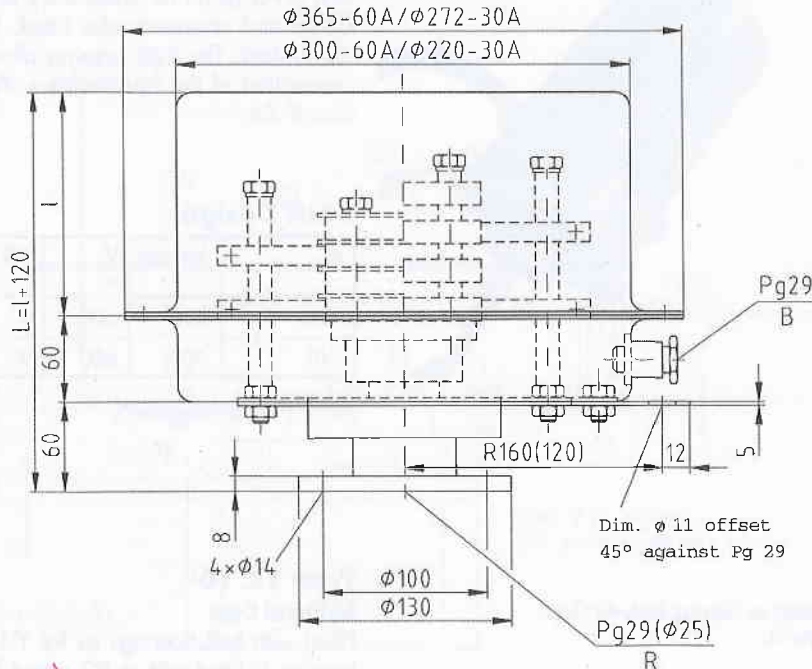

Type YK 21¹⁾

Technical Data

Fitted with ball bearings as YU 21. The housing is fitted with a PG gland for cable entry to brushes. Chain and clasp are also fitted, (no rigid connection). The high housing allows better connection of the brushholders. Protection class IP 54.

Basic Design

A	Voltage V		YB	YL
	~	=		
10	230	280	X	
32	230	280	X	
36	500	600	X	X
42	500	600	X	X
60	500	600	X	X

Dimensions

Type of Housing YK 21		Length of Gap l in mm							
		100	150	200	250	300	350	400	500
With Sliprings	Cable Cross-section	max. No. of Poles							
		YB	1,5 mm ²	5	8	12	16	20	24
YL	1,5 mm ²	3	6	8	11	13	16	18	23
YB	4,0 mm ²	3	7	10	13	16	19	21	-
YL	4,0 mm ²	2	4	6	9	11	13	15	19

Shaft Clearance: Note no. of poles and cable cross-section

¹⁾ Dimensions unbinding
R = Cable entry to rings
B = Cable entry to brushholders



Slipring Bodies

Rotating with Bearings, Enclosed, Protection Class IP 54,
Type YK 36 with Oscillating Brushholders

Type YK 36

Design as Slipring Body-Block
Type YB

Design as Slipring Body-Air Gap
Type YL

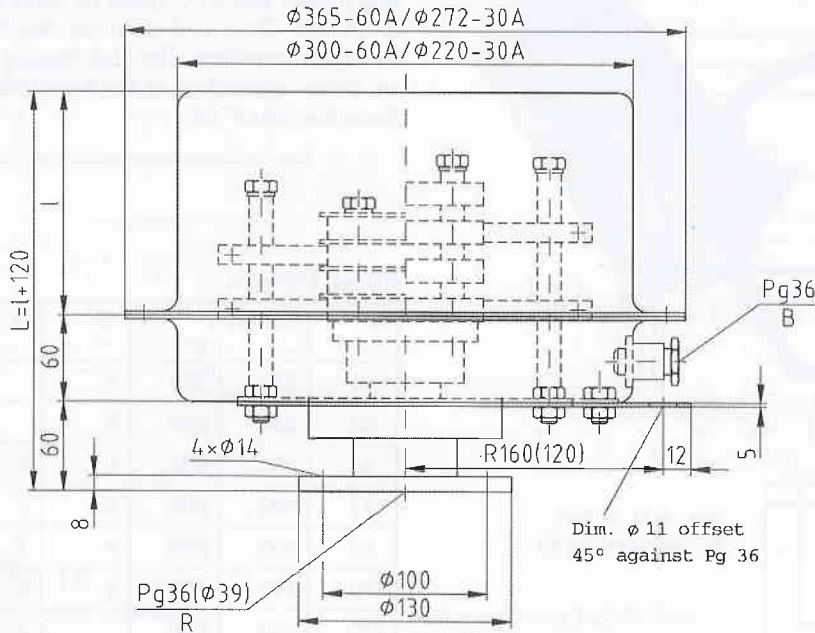

Type YK 36¹⁾

Technical Data

Fitted with ball bearings as YU 36. The housing is fitted with a PG gland for cable entry to brushes. Chain and clasp are also fitted, (no rigid connection). The high housing allows better connection of the brushholders. Protection class IP 54.

Basic Design

A	Voltage V		YB	YL
	~	=		
10	230	280	X	
32	230	280	X	
36	500	600	X	X
42	500	600	X	X
60	500	600	X	X

Dimensions

Type of Housing YK 21		Length of Gap l in mm							
		75	150	200	250	300	350	400	500
With Sliprings	Cable Cross-section	max. No. of Poles							
YB	1,5 mm ²	6	10	15	18	21	25	29	37
YL	1,5 mm ²	3	7	9	12	14	17	19	24
YB	4,0 mm ²	3	8	11	14	18	21	24	30
YL	4,0 mm ²	2	5	7	9	11	13	15	19

Shaft Clearance: Note no. of poles and cable cross-section

¹⁾ Dimensions unbinding
R = Cable entry to rings
B = Cable entry to brushholders



Slipring Bodies

Rotating with Bearings, Protection Class IP 54,
Type YK 48 with Oscillating Brushholders

Type YK 48

Design as Slipring Body-Black
Type YB

Design as Slipring Body-Air Gap
Type YL

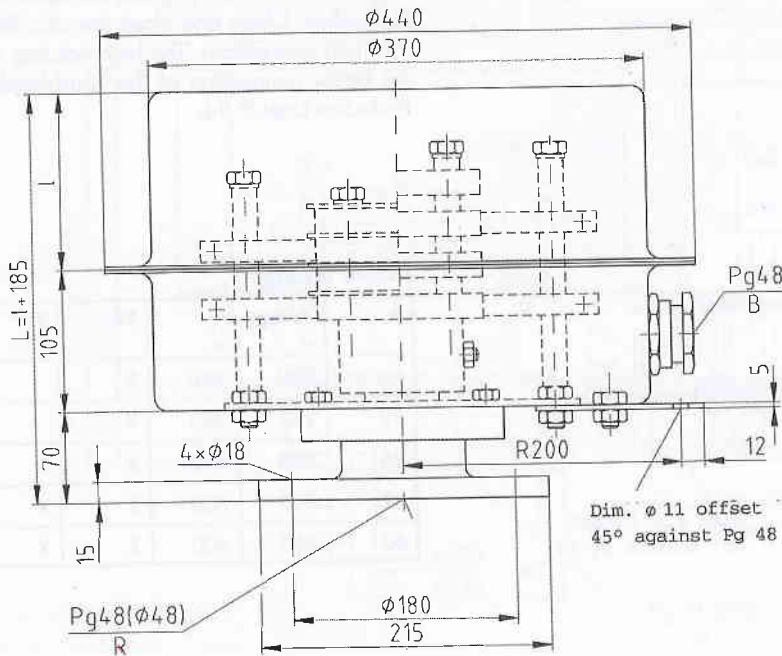

Type YK 48¹⁾

Technical Data

Fitted with ball bearings as YU 48. The housing is fitted with a PG gland for cable entry to brushes. Chain and clasp are also fitted, (no rigid connection). The high housing allows better connection of the brushholders. Protection class IP 54.

Basic Design

A	Voltage V		YB	YL
	~	=		
10	230	280	X	
32	230	280	X	
36	500	600	X	X
42	500	600	X	X
60	500	600	X	X
150	500	600	X	X
220	500	600		X

Dimensions

Type of Housing YK 21		Length of Gap l in mm							
		100	150	200	250	300	350	400	500
With Sliprings	Cable Cross-section	max. No. of Poles							
YB	16 mm ²	5	7	10	12	14	17	19	25
YL	16 mm ²	3	5	6	9	10	12	14	17
YB	50 mm ²	2	4	5	7	8	-	-	-
YL	50 mm ²	2	3	5	7	8	-	-	-

Shaft Clearance: Note no. of poles and cable cross-section

¹⁾ Dimensions unbinding
R = Cable entry to rings
B = Cable entry to brushholders



Slipring Bodies

Rotating with Bearings, Protection Class IP 54,
Type YK 80 with Oscillating Brushholders

Type YK 80

Design as Slipring Body-Block
Type YL

Design as Slipring Body-Air Gap
Type YL

Type YK 80¹⁾

Technical Data

Fitted with ball bearings as YU 80. The housing is fitted with a PG gland for cable entry to brushes. Chain and clasp are also fitted, (no rigid connection). The high housing allows better connection of the brushholders. Protection class IP 54.

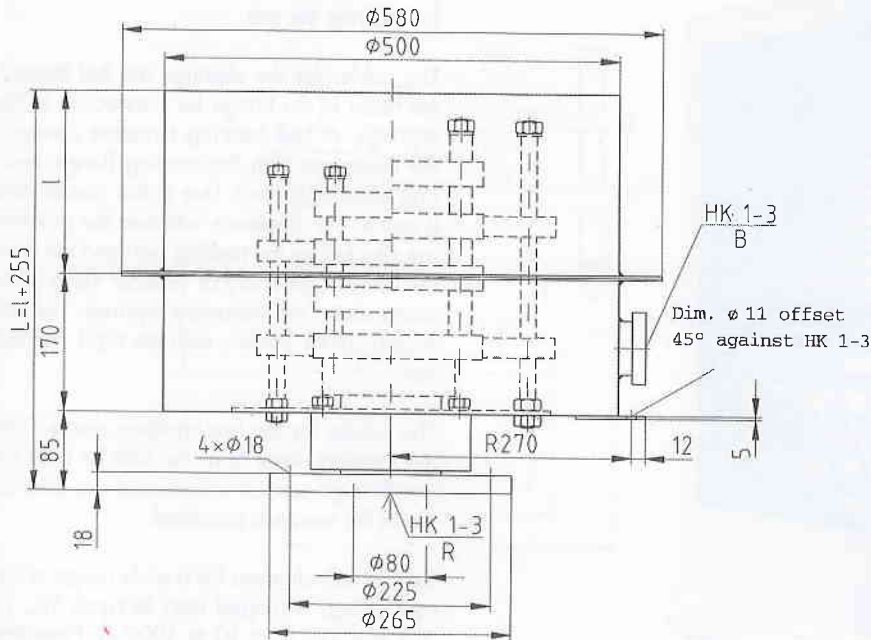

Basic Design

A	Voltage V		YB	YL
	~	=		
10	230	280	X	
32	230	280	X	
36	500	600	X	X
42	500	600	X	X
60	500	600	X	X
150	500	600	X	X
220	500	600	X	X
500	500	600		X
1000	500	600		X

Dimensions

Type of Housing YK 21		Length of Gap l in mm					
		170	250	300	350	400	500
With Sliprings	Cable Cross-section	max. No. of Poles					
YB	95 mm ²	4	5	6	7	8	10
YL	120 mm ²	3	4	5	6	7	9
YL	150 mm ²	2	3	4	5	6	8

Shaft Clearance: Note no. of poles and cable cross-section

¹⁾ Dimensions unbinding
R = Cable entry to rings
B = Cable entry to brushholders



Slipring Bodies

Rotating with Bearings, Enclosed, Protection Class IP 54,
Type YKD with Oscillating Brushholders

Dimensions YKD 125/150

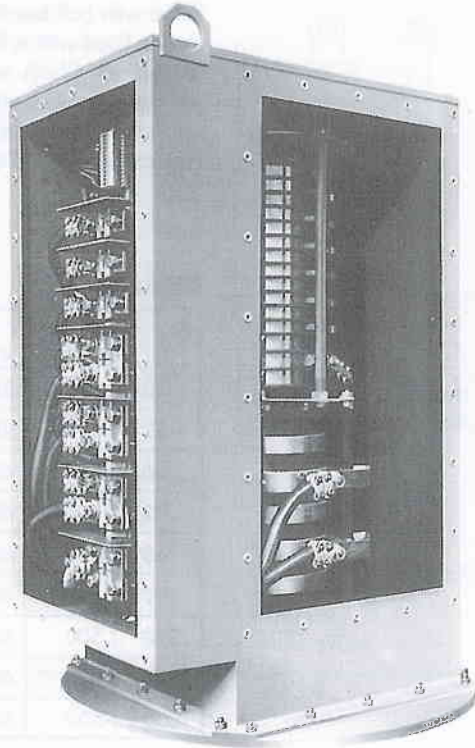

Type YKD 125/150¹⁾

Technical Data

Design as YUD 125/150. A large flange for mounting the slipring body onto the existing plate, king pillar etc. is provided with holes for securing the unit.

The cables for the sliprings are fed through the holes in the flange for connection to the sliprings. A ball bearing turntable connects the baseplate with the rotating flange ensuring exact alignment. Due to this construction it makes no difference whether the sliprings are situated on the rotating part and the brushes remain stationary or whether the brushes rotate round the stationary sliprings. The unit should rotate freely - with no rigid connection.

The cables for the brushholders are fed into the housing either from the side or from the top through special screws and are connected to the terminals provided.

Design with sliprings for a wide range of current ratings arranged acc. to types YB, YL, YLB and YLC from 10 to 1000 A. Protection class IP 54.

Slipring Bodies, Rotating with Bearings, Enclosed, Protection Class IP 54 10 to 1000 Amp.

Type YKD

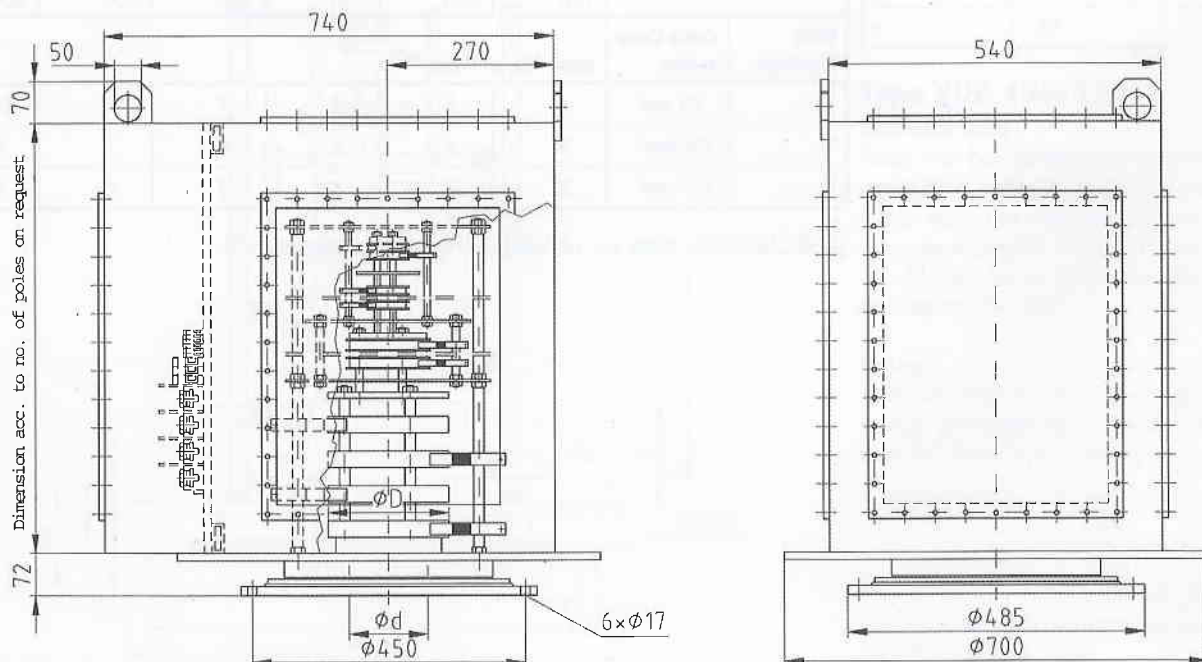

¹⁾ Dimensions unbinding



Slipring Bodies

High Voltage, Enclosed, Protection Class IP 54,
Type YKH... (up to 20 kV), with Oscillating Brushholders

Dimensions YKH for 10 KV¹⁾ (YKH up to 20 kV on request)

Technical Data

Operating voltage up to 20 kV. Brass sliprings, not split or copper profile. Brushholder per ring with 2 high quality swivelling bronze impregnated carbon brushes. Insulation by special epoxy ribbed insulators. Connections are tension relieved. Cable entries are designed to be cast in.

For outdoor mounting a thermally regulated heater can be fitted. Separated high and low voltage construction on request. Marine duty design with special sealing acc. to IP 56. Maintenance and mounting openings are fitted with double contact protection (lattice) acc. to VDE.

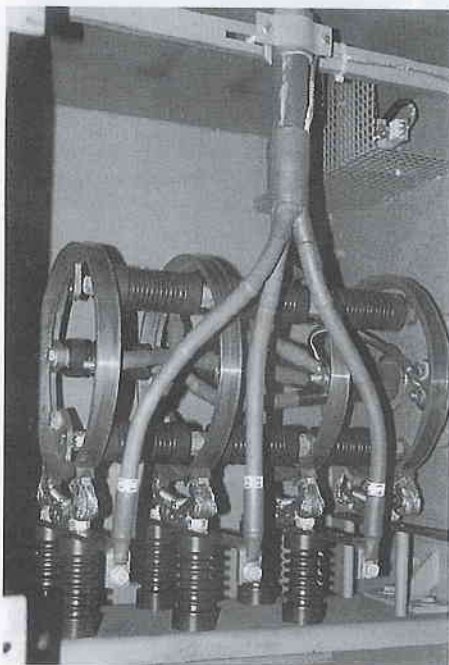
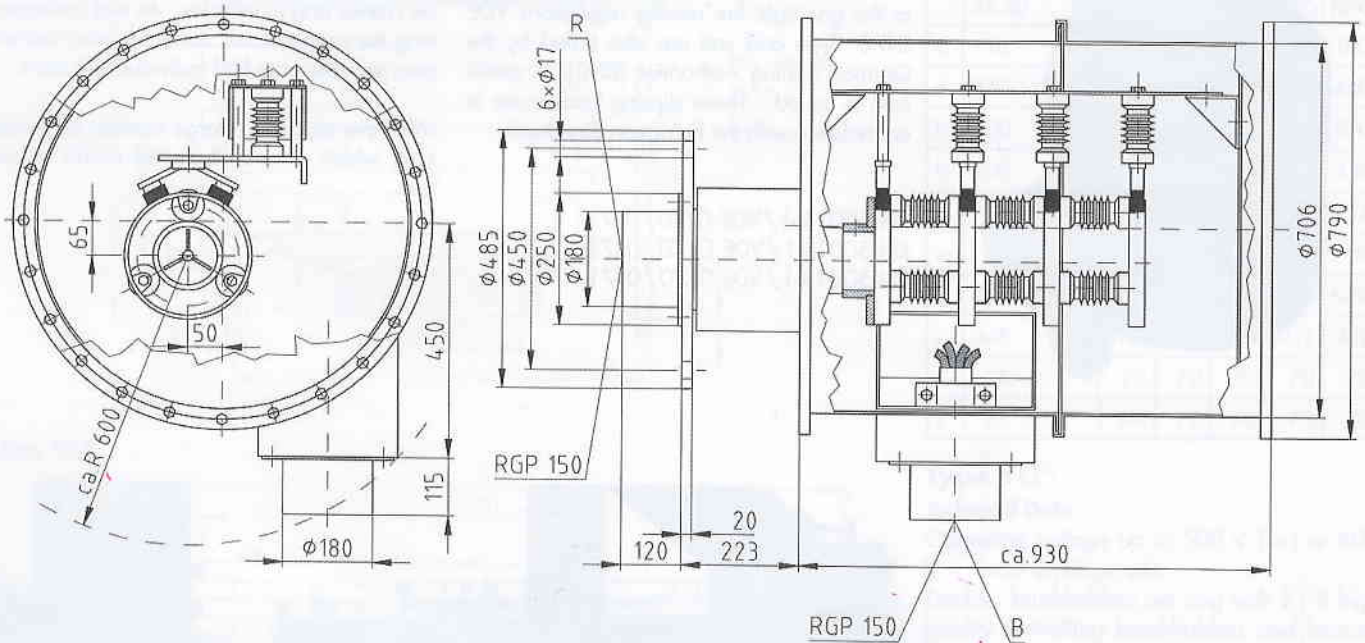

¹⁾ Dimensions unbinding
R = Cable entry to rings
B = Cable entry to brushholders



Slipring Bodies

Gas tight for Firing Mines and Explosion Proof acc. to VDE (Sch) d/Ex d 2 G3 and Euro. Standard EEx. de I/II



The slipring bodies for the designs Sch/d Ex /d and EEx.de I/II were designed to withstand very hard and severe duty and can be used for areas of application with high temperatures and extreme cold (built-in thermally regulated heating).

The slipring bodies are designed acc. to the German Ex regulations VDE 0171 and acc. to the gas tight fire mining regulations VDE 0170. Type and unit are also tested by the German Mining Authorities (DMT). A certificate is issued. These slipring bodies are in accordance with the European Standards.

EN 50014-1/VDE 0170/0171
EN 50018-1/VDE 0170/0171
EN 50019-1/VDE 0170/0171

These units are used extensively in areas where these hazard regulations apply e.g. in chemical plants, storage tanks, sewers, oil refineries, on offshore floating drill rigs, on ships, in underground mines and for special vehicles.

The slipring bodies are designed for mounting in cable reeling drums, in machinery, on cranes and in vehicles. As well as increasing the range of our standard units, we will also endeavour to find individual solutions.

We have supplied a large number of special units which are not illustrated in this catalogue.

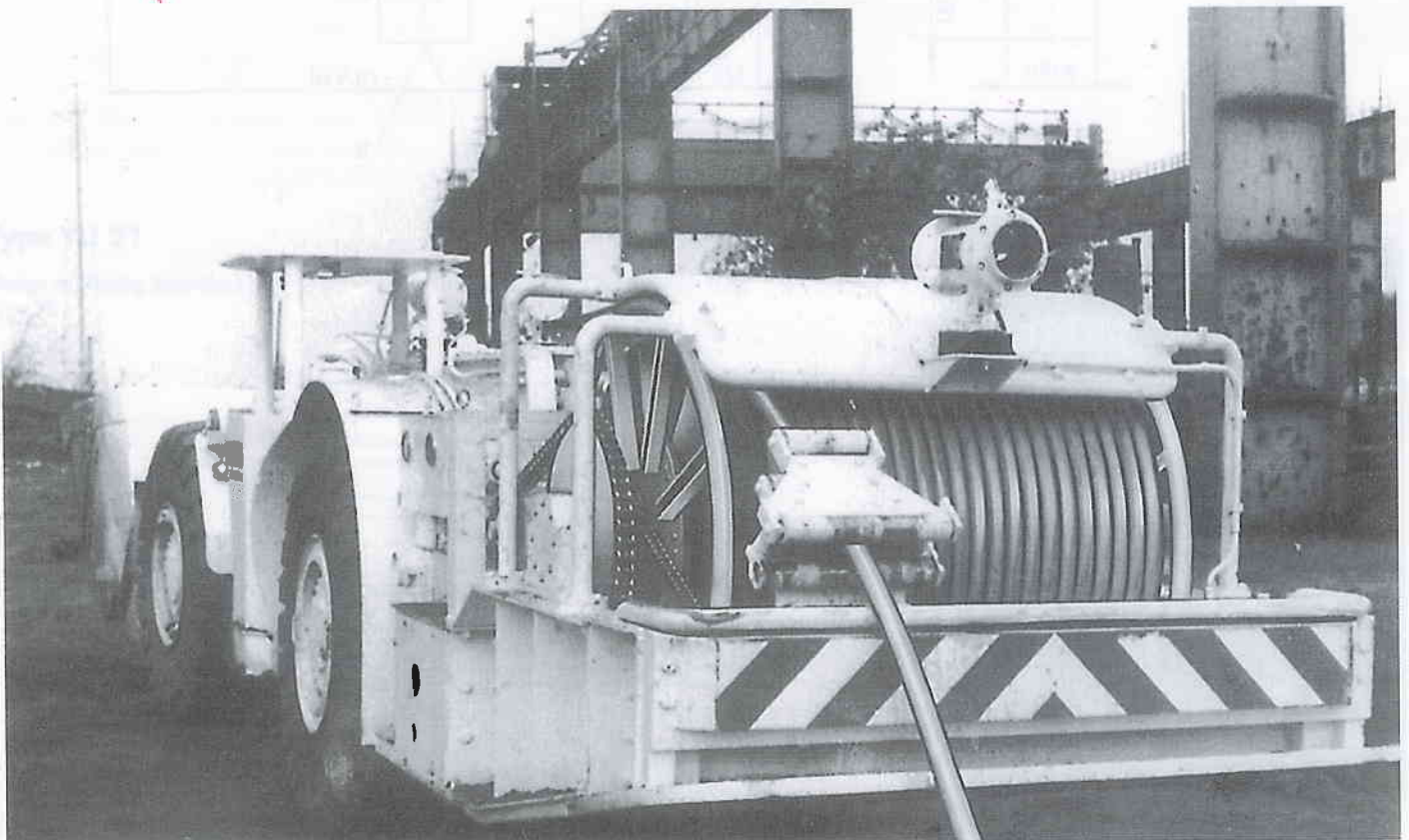

Cable Reeling Drum with installed Slipring Body for Ex Proof and Gas Tight Fire Mining



Sliprings Bodies

For Firing Mine, Hazardous Areas and Flameproof Enclosure acc. to the Harmonised European Standards



Type YKE 25

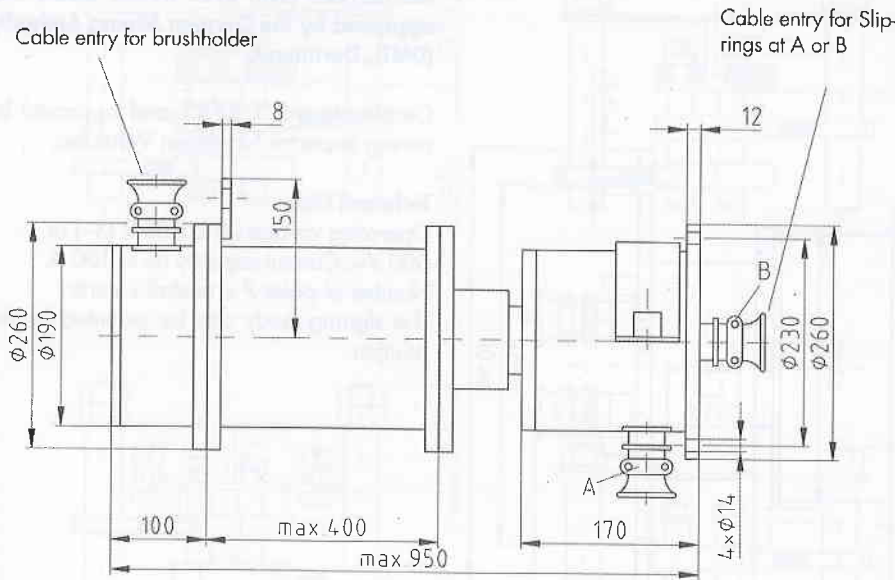

Type YKE 25¹⁾

Gas tight for firing mines and Ex proof acc. to VDE (Sch) d/Ex d2G3. Tested and approved by the German Mining Authority (DMT), Dortmund.

Certificate no. T 6342/T6466 and approval by mining inspector Nordrhein Westfalen.

Technical Data

Operating voltage up to 500 V (3~) or 600 V=.

Current capacity up to 26 A.

Number of poles up to 25 (for 1,5 mm²). The slipring body can be mounted in any position.

Higher no. of poles on request.

Type YKE 25/1¹⁾

Explosion proof acc. to European Standard EEx.de.IIB.T3. Tested and approved by the German Mining Authority (DMT), Dortmund.

Certificate of conformity DMT No. 87.011

Technical Data

Operating voltage up to 230 V or 380 V=.

Number of poles up to 15 x 32 A

The slipring body can be mounted in any position.

Type YKE 63

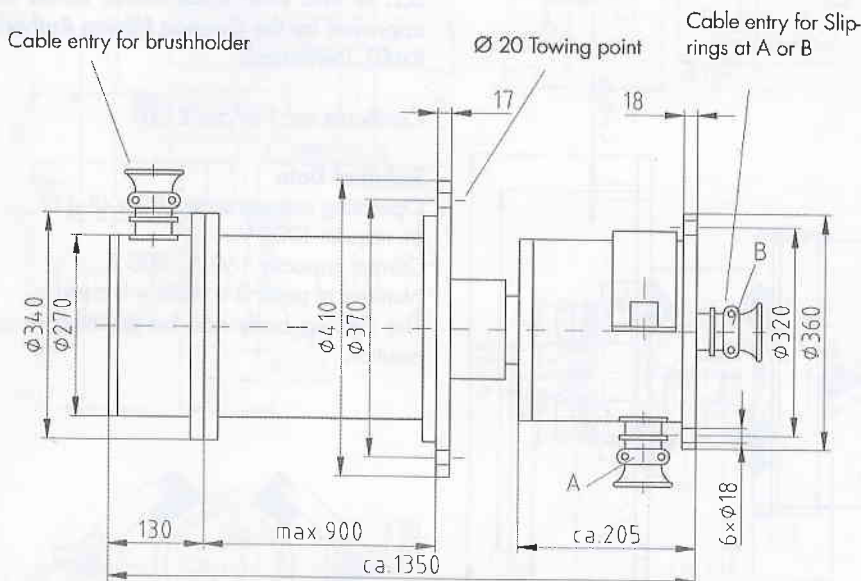

Type YKE 63¹⁾

Gas tight for firing mines and Ex proof acc. to VDE (Sch) d/Ex d2G3. Tested and approved by the German Mining Authority (DMT), Dortmund.

Certificate no. T 6250/T6248 and approval by mining inspector Nordrhein Westfalen.

Technical Data

Operating voltage up to 500 V (3~) or 600 V= (1000 V=).

Current capacity up to 63 A.

Number of poles as required.

The slipring body can be mounted in any position.



Sliprings Bodies

For Firing Mine, Hazardous Areas and Flameproof Enclosure acc. to the Harmonised European Standards



Type YKE 100

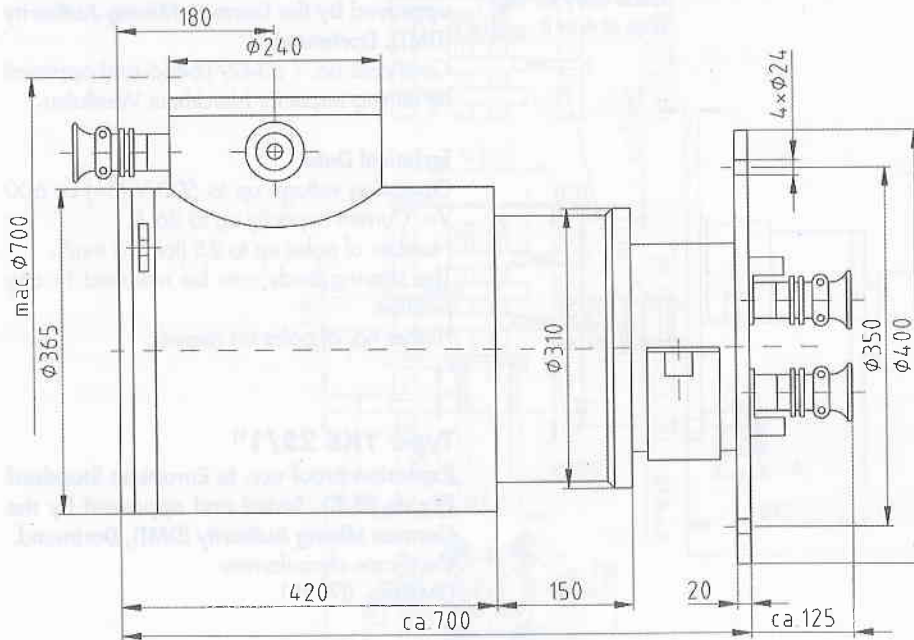

Type YKE 100¹⁾

Gas tight for firing mines and Ex proof acc. to VDE (Sch) d/Ex d2G3. Tested and approved by the German Mining Authority (DMT), Dortmund.

Certificate no. T 5755 and approval by mining inspector Nordrhein Westfalen.

Technical Data

Operating voltage up to 500 V (3~) or 600 V=. Current capacity up to 100 A. Number of poles 7 + neutral + earth. The slipring body can be mounted in any position.

Type YKE 200

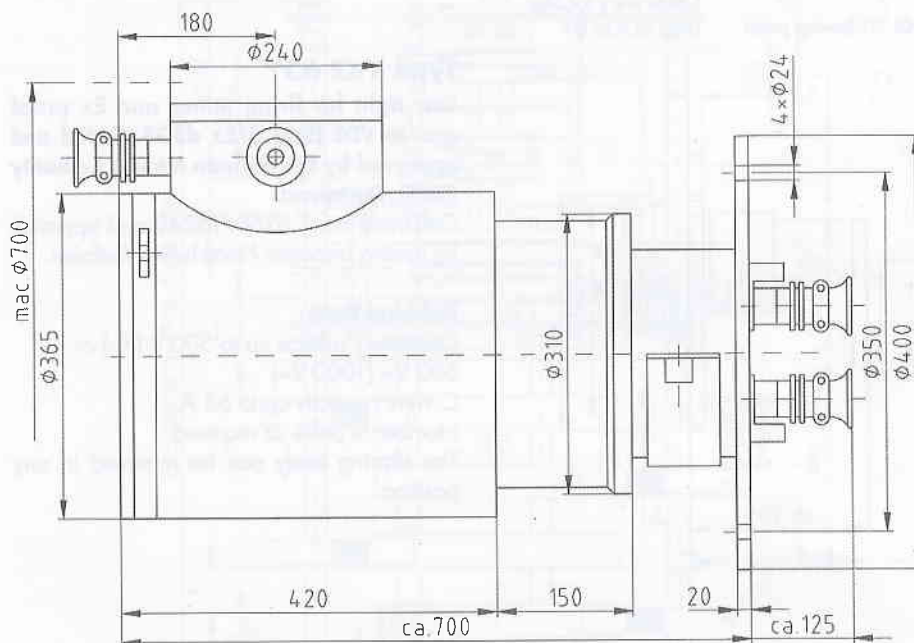

Type YKE 200¹⁾

Gas tight for firing mines and Ex proof acc. to VDE (Sch) d/Ex d2G3. Tested and approved by the German Mining Authority (DMT), Dortmund.

Certificate no. T 5755/Z1-Z6.

Technical Data

Operating voltage up to 500 V (3~) or on request 1000 V. Current capacity 160 A - 200 A. Number of poles 3 + earth + 2 controls. The slipring body can be mounted in any position.



Slipping Bodies

Rotating, Type YSW, Single Pole for Welding,
Type YSK, Rotating for Measuring Circuit

Type YSW

Technical Data

This rotating slipping unit, which is fastened to a shaft with a conical clamp sleeve, is intended specially for machines and devices for welding. Flexible cables or copper braid must be used for connection. For higher currents several devices can be arranged parallel on the shaft.

We can also supply units for multipole current transmission. The indicated values refer to a max. number of rotations of 10 min⁻¹.

Max. number of rotations 1 000 000.

It is necessary to observe the change of grease.

Higher current capacities and number of rotations on request.

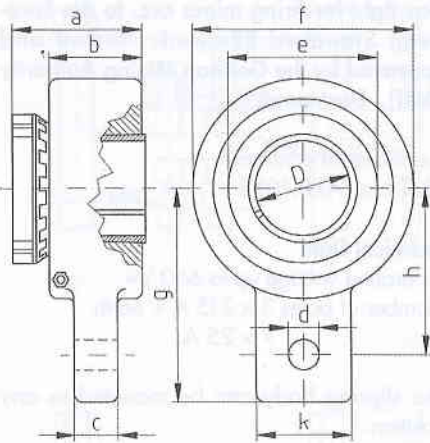

Dimensions YSW¹⁾

Current A	V	Ø D	Ø d	Ø e	Ø f	a	b	c	g	h	k	Torque		Weight kg
												Nm	min ⁻¹	
400	60	40	13	65	98	54	40	18	95	72	40	6	10	2,8
600	60	50	13	75	110	59	42	18	105	83	40	7	10	3,2
800	60	60	13	85	125	59	42	20	115	92	40	9	10	4,0
1200	60	70	17	105	140	64	43	20	125	98	48	11	10	5,6
2000	60	70	17	105	145	64	44	20	130	102	48	12	10	6,3

Type YSK

Technical Data

These slipping units are intended for transmission of measuring signals in rotating equipment. All types of measuring instruments can make use of our units. The symmetric arrangement of the brushes compensates largely the thermocouple potential between slipping and brushes. The slipping head itself is made of a stator with two brushholders with gold spring and with goldplated slippings. The brushholder banks can be easily lifted off the slippings and reset by rotating the adjustment ring. This can be done also when the shaft is rotating. Electrical connection is by terminals for soldering.

Dimensions YSK¹⁾

Ø D	Current A				
	0,5	1	2	5	10
	Max. cores				
51,5					4
63,5				12	6
75,5				16	8
94			32	22	11
108			40	26	13
121,5		46	46	28	15
168,5	94	70	70		
206,5	106	80	80		
233,5	144	92			
327,5	188	140			

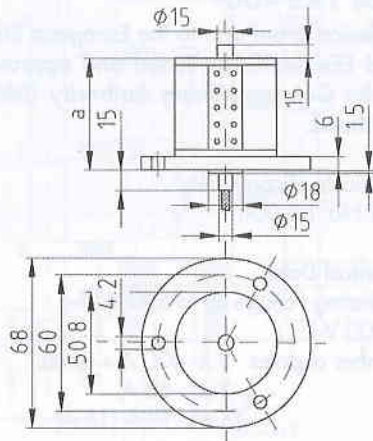

¹⁾ Dimensions unbinding



Slipring Bodies

Components

Slipring Bodies Block Type YB¹⁾

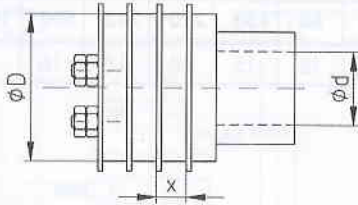

Current Capacity	10	26	32	36	40	42	60	150	220
Outer ϕ D	80	50	80	80	50	80	80	130	130
Hole ϕ d	55	30	55	55	25	55	55	80	80
Distance x	6	12	8	12	12	12	14	17	22

Slipring Bodies Air Gap Type YL¹⁾

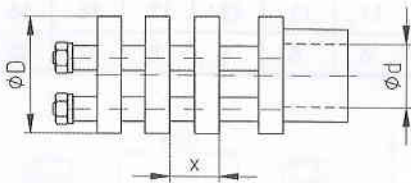

Current Capacity	26	32	36	40	42	60	150	220	265	500
Outer ϕ D	50	80	80	50	80	80	130	130	200	200
Hole ϕ d	30	55	55	25	55	55	80	80	100	100
Distance x	20	18	20	20	20	22	25	30	58	58

Sliprings¹⁾

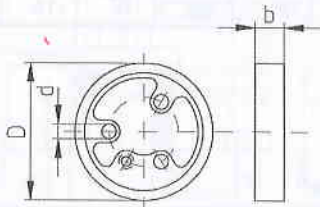

Current Capacity	10	26	32	36	40	42	60	150	220	265	500	1000
Outer ϕ D	80	50	80	80	50	80	80	130	130	200	200	340
Width b	4	10	6	10	10	10	12	15	20	28	28	30
Phase ϕ d	11,5	8,5	11,5	11,5	8,5	11,5	11,5	12,5	12,5	16,5	16,5	16,6
Earth ϕ d	11,5	5,5	11,5	11,5	5,5	6,5	6,5	8,5	8,5	12,5	12,5	12,5

Complete Brushholder Device¹⁾

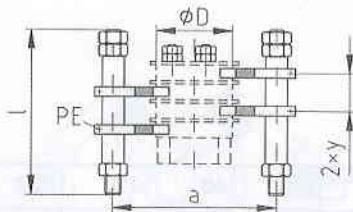

Current Capacity	10	26	32	36	40	42	60	150	220	265	500	1000
ϕ D	80	50	80	80	50	80	80	130	130	200	200	340
a	133	104	133	133	104	133	150	224	224	300	300	460

Phase Brushholders¹⁾

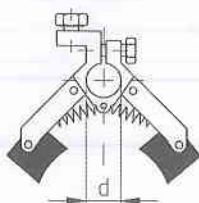

Current Capacity	10	26	32	36	40	42	60	150	220	265	500	1000
Dimension ϕ d	-	10	10	10	10	10	13	16	17	17	17	17

¹⁾ Dimensions unbinding



Slipring Bodies

Components

Type 11, 35 A

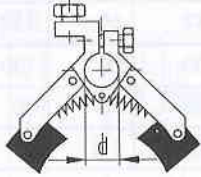

Brushholders Earth¹⁾

Current Capacity	10	26	32	36	40	42	60	150	220	265	500	1000
Dimension $\varnothing d$	-	8	8	8	8	8	12	15	16	16	16	16

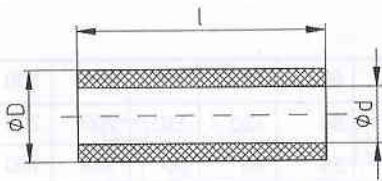

Insulating tube for Sliprings¹⁾

Current Capacity	10	26	32	36	40	42	60	150	220	265	500
Outer $\varnothing D$	11	8	11	11	8	11	11	12	12	16	16
Hole $\varnothing d$	6	5	6	6	5	6	6	8	8	12	12

Please state length when ordering

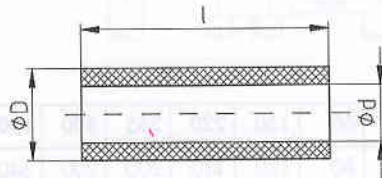

Distance tube for sliprings¹⁾

Current Capacity	26	32	36	40	42	60	150	220	265	500
Outer $\varnothing D$	10	16	16	10	16	16	16	17	25	25
Hole $\varnothing d$	8	12	12	8	12	12	12	12	16	16

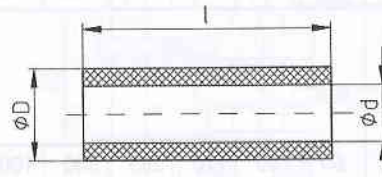

Insulating tube for Brushholder Device¹⁾

Current Capacity	26	32	36	40	42	60	150	220	265	500
Outer $\varnothing D$	10	10	10	10	10	13	16	17	17	17
Hole $\varnothing d$	8	8	8	8	8	8	12	12	12	12

Please state length when ordering

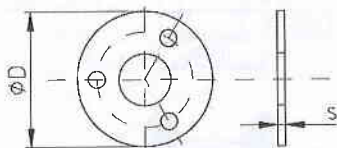

Insulating Disc¹⁾

Current Capacity	10	26	32	36	40	42	60	150	220
Outer $\varnothing D$	88	58	88	88	58	88	88	145	145
Thickness S	2	2	2	2	2	2	2	2	2

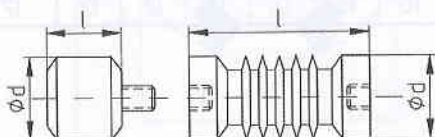

Insulators¹⁾

For spare parts delivery please state outer \varnothing and length l.

¹⁾ Dimensions unbinding



Questionnaire for Slipping Bodies

The construction of the slipping body depends on the conditions of application. For correct assessment the following questions should be answered.

Amount required _____

Annual demand _____

I Mechanical Requirements

1. Mounting

1.1 Open design without bearings
(brushholders supplied separately)

like e.g. type YL air gap type

or like type YB block type

Rotating with bearings, i.e. brushholders are mounted on ball bearings on the base of the slipping unit.

like e.g. type YU open design,
protection type IP 00

1.3 Enclosed design i.e. with complete steel housing,

like e.g. type YK

or type YKD

standard protection class IP 54.

1.4. Mounting conditions, type of fastening, if possible drawing or sketch, max. permissible dimensions, information on application of slipping body.

2. Are there strong vibrations

yes

explanation _____

no

3. Ambient temperature _____ °C.

Variations in temperature

yes ± _____ K

no

4. Mounting height from 1000 m above sea level

or underground _____

marine design _____

5. Relative humidity _____ %

6. Ambient conditions

Normal surroundings

Coal dust

Salt water

Sand dust

Underwater

Other conditions

Aggressive vapours

7. Protection class acc. to DIN 40 050, Bl. 1 and IEC 144

IP _____

8. Diverse regulations

Ex

Firing gas

Ship classification _____

9. Rotations per min. _____

10. Max. rotary angle in °C. _____

11. Finish

Under and overcoat
acc. to RAL 7031
(normal design)

Galvanised

Sandblasted

Other surface
treatment

Notes



Questionnaire for Slipping Bodies

II Electrical data

12. What type of cable entry is required?

Pg. gland

Entry seal combinations such as RGP frame type gland

Other _____

13. Type of current

DC (=)

3 phase AC (3~)

14. Max. operating voltage _____ V

Test voltage _____ V

Control voltage _____ V

15. Rated current _____ A

Control current _____ A

16. Starting current _____ A

Duty cycle _____ % ED

17. Frequency of current _____ Hz

High frequency _____ kHz

Number of poles _____

How many Baud are transmitted through computer in the slipping system?

18. How many insulated slirings are required?

Is a slirring for earth (PE) required?

yes

no

Is an insulated neutral (MP) required?

yes

no

19. Cable cross-sections _____ mm²

Cable diameter _____ mm²

20. For control

Slirings with wire brushholders (10A), (not for cable reeling drums)

Slirings in normal design: (brass rings with bronze impregnated carbons)

Silver-plated slirings with ca. 30-50 μ and silver impregnated carbons

Gold-plated slirings with gold impregnated carbons

Screened slirings

in pairs _____ no.

single _____ no.

21. Terminal strips for slirings and brushes

Wires to slirings prepared

Wires to slirings and brushes prepared

22. With thermic regulated heating.

Notes



Technical Explanatory Notes

For spring and motor driven cable reeling drums and slipping bodies

Instructions for Cable Reeling Drums and Slipping Bodies

Cable reeling drums are suitable for use with both horizontal payout in one or both directions and vertical payout downwards or upwards from a feed point. We ask you therefore to observe our questionnaire (page 36) as well as our arrangement examples. Our cable reeling drums and slipping bodies are manufactured in accordance with the specifications.

Use and Choice of Cable Reeling Drums

We supply cable reeling drums and slipping bodies with the following drive units:

1. Drive by helical springs, types LT, LT Sch, LTA, LTB, LTS (slippingless), etc.
2. Drive by counterweight, type **KTG**.
3. Drive by electric motor with hydraulic coupling, type **M**.
4. Drive by electric motor with permanent magnetic coupling, type **H**.
5. Drive by electric motor as stalled torque motor, type **K** (squirrel cage motor) and **S** (slipping motor).
6. Drive by induction type magnetic coupling.
7. **Slipping bodies:** open design, closed design, rotating slipping bodies and slipping bodies in type Ex.d.Sch. or EEx.de.I/II.

The correct selection of the type of drive for a cable reeling drum depends on a number of factors. Due to our wide choice of drives, we are in a position to offer the correct unit most suitable for your application.

We have enclosed a questionnaire (page 36) with this catalogue which, if completed properly, will enable us, when making you an offer, to consider all factors which are required for perfect functioning of a cable drum or slipping body.

On page 35 you will find arrangement examples showing various ways of mounting the cable reeling drum onto the device. We advise you to give detailed information in your enquiry and if possible to enclose any drawings so that we can make the best suggestions as to the installation.

Arrangement of Cable Reeling Drums

The cable reeling drum must be mounted in such a way that even after overtravelling of the centre feed point, free and unobstructed payout and pickup of the cable is assured. Cable deposit should be between max. 0,5 m to 2,5 m below the drum shaft either inside or outside the travel rails. Mounting drums at higher levels is also possible but please inform us if this is the case.

Selection of Trailing Cable and Cable Feed Point

Depending on the position of the feed point, all cable reeling drums can payout in one or both directions from the feed point. If the feed point is at the end of travel, the length of the cable must be the full length of travel. If the feed point is in the centre, the length of the cable is only half the length of travel. In both cases, two dead coils must remain on the drum for tension relief. The required cable length is calculated as follows:

$L_{erf.} = \text{actual payout length} + 2 \text{ dead coils on the drum for tension relief} + \text{distance from feed point to terminal boxes} + \text{length from drum to slippings} + \text{mounting height of drum.}$
The listed payout lengths must not be exceeded as this could lead to damaging of the helical springs in spring driven drums.

Selection of Trailing Cables

When purchasing trailing cables, the supplier must be informed of the following:

- a) the cable will be used on drums with continuous flexing stresses and will be guided and deflected
- b) the cable must conform to the minimum requirements of VDE with regard to bending diameters and tensile stresses.

The data indicated by us such as diameter, weight, cross-section, diameter of drum core, bending radii at deflection and curves conform to VDE specifications or for security reasons exceed them. All values are in accordance with the VDE specifications VDE 0100 ie. VDE 0165. Due to the high wear and tear at the site of application, the special cables (usually expensive) manufactured by some companies, have a higher life duration and have proved to be the most suitable for winding onto drums. Tests and performance data were carried out using the cable type NSHTÖUKJ ie. NSHTÖUJ. The static continual tensile stress, related to the whole copper cross-section of the conductor, is to be considered when choosing the cable cross-section. The tensile stress is reduced with concentric cables. The pull on the cable, as mentioned in our catalogue, refers to ambient temperatures of + 40° to - 15°. A higher pull is necessary at lower temperatures because of the stiffness of the cable.

Coiling the Cable onto the Drum

The drum duty cable must be coiled onto the drum body totally twistfree. Please observe our operating and maintenance instructions.



Technical Explanatory Notes

For spring and motor driven cable reeling drums and slipping bodies

Please note!

The cable to be accommodated on the drum should never exceed the length that is indicated on the nameplate. Two additional turns of cable must always be maintained on the drum body for tension relief. These two coils have been calculated into the carrying capacity of the drum body. Please see the operating and maintenance instructions which are enclosed with each cable reeling drum.

Control Cables

All cable reeling drums can be fitted with multipole slipping units to suit multicore control cables. The number of cores and cross-section of the cable determine the structure of the slipping body.

Operating Voltage

The cable drums and slipping bodies are suitable for up to 500 V A.C. (3Ph) or 600 V D.C. (=) and drive motors with 400 V three phase current (3Ph), 50 Hz. If a higher operating voltage is required, please state this in your enquiry.

Current Capacity

Our standard is for 100% duty cycle for the rated current carrying capacities.

Earth

All our slipping bodies and cable drums are fitted with an uninsulated earth ring PE. The number of poles is the number of insulated poles eg. 3 poles + earth or 11 poles + earth. The earth ring looks different to the phase rings. The two types are not allowed to be mixed up.

Drum Body

The drum bodies can be of the cylindrical type or of the spiral type. In order to assure perfect ventilation of the cable, the larger drum bodies are provided with a perforated sheet metal casing. The flanges for the larger drums are of spoke design.

Limit Switches

It is possible to additionally fit limit switches to all types of drums. This switch cuts the power supply through the control cable of the crane. (Do not use as a security switch to stop the crane at the end of the track).

For centre feed, the following points are to be noted:

1. For semi automatic operation a push button control must be provided by the customer to override the limit switches at the overtravel of the centre feed point (wiring diagrams on request).
2. On the mounting of a rocker arm with a change over switch on the centre feed funnel (over the control cable of the crane), the device can be fully automatically driven out of the end position.

Type of Protection

Our standard cable reeling drums and encapsulated slipping bodies are suitable for outdoor use (IP 54).

IP 54 means: complete protection against contact with or approach to live or moving parts inside the enclosure.

Protection against the harmful deposit of dust. The entering of dust is not totally prevented but large quantities of dust should not enter into the machine otherwise this could interfere with satisfactory operation.

Water splashing against the machine from any direction should not have any harmful effect, provided that the coiled cable and the cable lead to the slippings are properly sealed.

On request we can deliver other types of protection.

Acceleration

Standard cable drums are calculated for a max. acceleration of $a = 0,2 \text{ m/s}^2$. Higher acceleration can be accommodated on request. For the types KFM and KSM the max. acceleration is 1 m/s^2 .

Paint Finish

Cable reeling drums and enclosed slipping bodies are derusted by hand and then primed with resin primer. Finish is in blue-grey acc. to RAL 7031.

On request the following surface treatments can be carried out: other colours, sandblasting, lead primer, 2 component epoxy, galvanising, plastic coating and a special paint for marine specification.

Maintenance

Due to the simple structure, the cable drums need little maintenance. All bearings are greased. Ball bearings operating at higher ambient temperatures require special attention as stated in our operating and maintenance instructions. The gear boxes and hydraulic and magnetic couplings require an oil change or lubrication as stated in the operating instructions. Motor lubrication is in accordance with the manufacturer's specification.

The carbon brushes in the slipping bodies are subject to natural abrasion and should be cleaned accordingly and replaced when 2/3 of the carbon has worn down. The holding brake must be checked from time to time.

Ambient Conditions

Adverse conditions are often the case and must therefore be considered when ordering a cable drum.

Please consider the following points: extreme high and low temperatures, large variation in temperature, operation at high elevation, high humidity, strong vibrations, pollution in the air, operation at sea or in salty air and operation underground.

Liability for Faults

If, during the time of guarantee, infringements or repairs are made on the cable reeling drums by unauthorized persons, our liability for guarantee becomes null and void.

Note:

We would like to point out that acc. to the EC specification 89/392/EWG, rotating parts, such as drum bodies, must be secured against accidents.



Technical Explanatory Notes

Drum duty Trailing Cables acc. to DIN VDE 0100-726/A 1
Cable Data, Current Capacity, Conversion Factors

Cable data

Cross Section mm ²	3 core	
	Ø Diam mm	Weight kg/m
1,5	14,0	0,27
2,5	14,5	0,28
4	17,2	0,38
6	18,1	0,47
10	22,8	0,88
16	25,3	1,10
25	31,0	1,60
35	34,2	2,09
50	38,5	2,88
70	45,2	3,80
95	50,0	4,95
120	-	-
150	-	-
185	-	-

4 core		5 core	
Ø Diam mm	Weight kg/m	Ø Diam mm	Weight kg/m
14,6	0,29	15,0	0,32
16,2	0,30	18,6	0,49
19,3	0,49	20,5	0,64
21,7	0,58	23,0	0,86
25,9	0,98	27,8	1,2
29,1	1,37	31,7	1,57
34,4	2,05	39,5	2,43
38,6	2,57	42,0	3,08
45,0	3,60	-	-
51,0	4,62	-	-
60,6	6,50	-	-
63,5	7,70	-	-
66,5	8,06	-	-
72,5	9,95	-	-

7 core		12 core	
Ø Diam mm	Weight kg/m	Ø Diam mm	Weight kg/m
18,5	0,45	20,8	0,62
20,8	0,62	24,9	0,90

Cross Section		
cores mm ²	Ø Diam mm	Weight kg/m
8 x 2,5	21,0	0,66
18 x 2,5	28,2	1,19
24 x 1,5	28,0	1,10
24 x 2,5	33,0	1,57
30 x 2,5	34,6	1,83
45 x 1,0	35,5	1,71

Current Capacity Amp, (neglecting voltage drop)

Cross Section mm ²	Current Capacity at ...% duty cycle			
	100%	60%	40%	20%
1,5	23	23	23	23
2,5	30	30	30	30
4	41	41	42	45
6	53	54	55	62
10	74	76	80	97
16	99	106	115	143
25	131	144	161	208
35	162	183	208	274
50	202	234	270	361
70	250	294	409	467
95	301	361	427	581
120	352	425	506	693
150	404	493	589	811
185	461	567	681	940

The tabled values refer to single layer of cable. The values for 100% duty cycle are as per VDE 0100 sect. 523 and DIN 57100 sect 523 table 2. The current capacity is stated for insulated cables, group 2, for an ambient temperature of 30°C and conductor temperature of 60°C.

Conversion Factors

For decrease in current carrying capacity to allow for number of layers on drum

Number of layers on drum	1	2	3	4	5
Conversion factor	0,8	0,61	0,49	0,42	0,34

for ambient temperature effect on current carrying capacity (4 core cables)

°C	Factor	°C	Factor
over 25 to 30	1,00	over 40 to 45	0,71
over 30 to 35	0,91	over 45 to 50	0,58
over 35 to 40	0,82	over 50 to 55	0,41

Multicore cables

Number of cores	5	7	10	14	19	24	40
Conversion factor	0,75	0,65	0,55	0,50	0,45	0,40	0,35

The factors for ambient temperature are as per table 3 of DIN 57100 and VDE 0100 sect. 523. The calculated values for intermittent service are empirical values. Please take the reduced capacity for multi layers of cable on the drum into consideration.

Calculating formulae

Ohm's Law	$U = I \cdot R$
Conductor temp.	$W = I^2 \cdot R \cdot t$
Resistance of a core (forward and return)	$R = \frac{2 \cdot l}{\chi \cdot A}$
D.C. output	$P = U \cdot I$
A.C. eff. output	$P = U \cdot I \cdot \cos \varphi$
A.C. 3ph. eff. output	$P = 1,73 \cdot U \cdot I \cdot \cos \varphi$
Efficiency	$\eta = \frac{P_{ab}}{P_{zu}}$

U	Operating Voltage in V (Volt) In two phase supplies between the two phases, in D. C. three phase supplies between the two main phases. In three phase A. C. supplies between the two main phases.
u	Voltage drop in Volt between the two ends of full cable length
I	Current in one phase Amp
R	Resistance in Ω (Ohm)
W	Work in Wattseconds
P	Output in Watt
P _{ab}	effective output in Watt
P _{zu}	effective input in Watt

η (Eta)	Efficiency
χ (Kappa)	Conductivity $\frac{S \cdot m}{mm^2}$ (e.g.: copper appr. 56)
cos φ (Phi)	Power factor
A	Cross section of core in mm ²
l	Full length of cable in mm
t	Time in sec.
v _{max}	Travel speed (U) or lift speed (vertical) in m/min

Voltage drop in Volt

at	for D.C. and single phase A.C. without induction cos φ = 1	3 phase A.C.
nominal current	$u = \frac{2 \cdot l \cdot I}{\chi \cdot A} (V)$	$u = \frac{1,73 \cdot l \cdot I \cdot \cos \varphi}{\chi \cdot A} (V)$
nominal output	$u = \frac{2 \cdot l \cdot P}{\chi \cdot A} (V)$	$u = \frac{l \cdot P}{\chi \cdot A} (V)$

Cross section of cores in mm²

at	for D.C. and single phase A.C. without induction cos φ = 1	3 phase A.C.
nominal current	$A = \frac{2 \cdot l \cdot I}{\chi \cdot u} (mm^2)$	$A = \frac{1,73 \cdot l \cdot I \cdot \cos \varphi}{\chi \cdot u} (mm^2)$
nominal output	$A = \frac{2 \cdot l \cdot P}{\chi \cdot u \cdot U} (mm^2)$	$A = \frac{l \cdot P}{\chi \cdot u \cdot U} (mm^2)$



General Conditions of Supply and Delivery for Products and Services of the Electrical Industry*)

I. Scope of supplies or services

1. The scope of supplies or services shall be governed by mutual declarations in writing. Where an agreement has been entered into without such mutual declarations either the written order confirmation by the Supplier or Performer (in the following: the Supplier) shall govern, or where such order confirmation has not been issued the written order of the Purchaser.
2. Protective devices will be supplied to the extent required by law or expressly agreed upon.
3. All supplies or services shall be governed by the rules of the Verband Deutscher Elektrotechniker (Association of German Electrical Engineers) insofar as safety of supplies or services is concerned. Deviations are permissible if the same safety standard will be achieved by different means.
4. Supplier reserves all titles and property rights and rights originating from copyright on cost estimates, drawings and other documents; such may not be disclosed to third parties without the prior consent of Supplier. All drawings and other documents pertaining to quotations shall immediately be returned on request if the order is not placed with the bidder. Foregoing sentences 1 and 2 shall apply accordingly to documents of Purchaser. They may, however, be made available to those third parties, which perform services or supplies for the Supplier in cases where this is permitted.
5. Additional agreements shall not be binding unless confirmed in writing.

II. Prices

Where supply offered does not include erection or installation, prices quoted are ex works, excluding packing.

III. Retention of title

Title on all goods is retained by Supplier until each and every claim of Supplier against Purchaser originating in the business relations has been duly satisfied. Prior to this event goods may not be pledged or given as security and may only be re-sold by resellers in the normal course of business, against payment from their Customers. Any costs incurred in connection with interventions following this Section shall be borne by Purchaser.

If the value of the sureties accruing to the Supplier in performance of sentence 1 exceeds the value of all privileged claims by more than 20%, Supplier shall upon request release a respective part of the sureties.

IV. Conditions of payment

1. Payments shall be made free paying-office of Supplier.
2. Purchaser may set off only such claims as are undisputed or finally determined.

V. Period for supply of deliveries or services

1. The period for supply of deliveries and services shall be governed by the mutual written declarations. Section I No. 1 Sentence 2 shall apply accordingly. Timely supply is conditioned upon timely receipt of all documents to be furnished by Purchaser, necessary licenses and releases, timely clarification and approval of plans and observance of the terms of payment agreed upon and all other obligations.

If these conditions are not timely fulfilled, the period for supply shall be appropriately extended.

2. Above period shall be deemed to have been met:
 - a) Where supply does not include erection of installation, if the goods, ready for operation, have been delivered to the carrier or picked up within the agreed period. If delivery is delayed for reasons for which the Purchaser is responsible, supply shall be deemed timely, if notice that goods are ready for shipment has been given within the agreed period.
 - b) Where supply includes erection or installation, if such erection or installation has been completed within the agreed period.

3. If the period for supply of deliveries or services can be proven to have been exceeded because of mobilisation, war, riot, strike, lockout or in the event of unforeseeable circumstances, such period shall be adequately extended.

If such period is exceeded for reasons other than those stated in subsection 3 para 1, the Purchaser - insofar as he can establish credibly that he has suffered damage owing to the delay - may claim liquidated damages of 1/2 % for every completed week's delay up to an overall total of 5 % of the value of that part of supplies or services which could not be taken into useful operation owing to individual components there of not having been furnished in time.

Purchaser shall likewise be entitled to liquidated damages in case of circumstances as described under subsection 3 para 1 arising only after period of supply of deliveries or supplies originally agreed upon has been culpably exceeded by Supplier. All further damages for delay as may be claimed by Purchaser exceeding the margin of 5 % as ruled under para 2 are expressly excluded even if an additional period of time as may have been granted to Supplier has expired. This does not apply where in cases of intent or gross negligence Supplier's liability is enforced by law.

The right of Purchaser to cancel the Contract after an additional period of time granted to the Supplier has ineffectively expired, shall remain unaffected.

4. If shipment or delivery is delayed at Purchaser's request, storage costs to the sum of 1/2 % of the invoiced amount may be charged for every month commenced beginning one month after notice has been given that goods are ready for shipment. Such charge shall be limited to an overall total of 5 % unless costs incurred can be proven to be higher.

VI. Transfer of risk

Risk shall pass to Purchaser, even if freight delivery paid has been agreed upon:

- a) Where supply offered does not include erection or installation: whenever goods ready for operation have been delivered to carrier or picked up. Every care shall be taken in packing. Shipment shall be carried out to the best of Supplier's judgement. At the request and expense of Purchaser, goods shipped will be insured by Supplier against breakage, damages in transit or fire.
- b) Where supply offered includes erection or installation: the day Purchaser has taken over goods for operation; insofar as a test run has been agreed upon,

whenever such run has been satisfactorily completed. Assumption hereto is that the test run or taking over for operation shall take place immediately following erection or installation declared ready for operation.

If Purchaser fails to accept the offer of a test run or to take over for operation, risk for the period of delay arising therefrom shall pass to Purchaser after a period of 14 days following such offer.

- c) If shipment delivery, commencement or execution of erection or installation is delayed at the request of Purchaser or for reasons within Purchaser's responsibility, risk shall pass to Purchaser for such period of delay. Supplier however undertakes to effect at Purchaser's expense such insurances as requested by Purchaser.

VII. Erection and Installation

A.

Insofar as nothing to the contrary has been agreed upon in writing the following provisions shall apply to erection and installation of any kind.

- a) Purchaser shall provide at his expense and in due time:

1. in sufficient number, auxiliary personnel such as labourers and, if necessary, bricklayers, carpenter, fitters, crane operators and other skilled labour along with the required tools;
2. all earth work, foundations, civil engineering, mortising, scaffolding, plastering, painting and other work not usual in supplier's trade including the necessary materials;
3. such objects and materials as are necessary for erection and putting into operation, e. g. props, wedges, bases, cement, cleaning and sealing materials, lubricants, fuel etc. furthermore scaffolds, lifting gear and other devices;
4. power water including the necessary connections up to point of use, heating and general lighting;
5. suitable and dry rooms of sufficient size at the site which can be locked for storage of machinery parts, equipment, materials, tools etc. as well as adequate working rooms and accommodation for Supplier's personnel including reasonable sanitary installations. Furthermore Purchaser must follow the same provisions for safeguarding the property of Supplier and erection personnel at the site as he would for his own;
6. protective clothing and protective devices which are necessary owing to particular conditions at site and which are not usual Supplier's trade.

- b) Before commencement of erection work, Purchaser must make available of his own accord necessary information concerning all concealed electric cabling, gas- or water-pipes and the like as well as necessary information on statics.

- c) Before commencement of erection or installation, the parts required for initiating the work must be at hand and all masonry, carpentry and other preparatory work must be so far advanced that erection or installation may begin immediately upon arrival of erection or installation personnel and proceed without interruption. In particular, the approach roads and the site for erection or installation itself must be level and clear, foundations must be dry and set, foundation walls



General Conditions of Supply and Delivery for Products and Services of the Electrical Industry*)

- c) erected and backfilled, and in the case of indoor work, the rendering of walls and ceilings must be complete and especially, doors and windows must have been fitted.
- d) If installation, erection or commencement of operation is delayed owing to circumstances particularly at the site the Supplier may not be held responsible for. Purchaser shall bear the reasonable costs for stand-by time and any additional travelling expenditures of erection or installation personnel.
- e) Working hours shall be certified at weekly intervals to erection or installation personnel by Purchaser to the best of his knowledge. Moreover, Purchaser shall immediately confirm in writing to erection or installation personnel completion of erection or installation work.
- f) Supplier shall not be liable for any work executed by his erection or installation personnel or other agents that are not related to supplies and erection or installation or insofar as it has been initiated by Purchaser.

B

If Supplier has undertaken to provide erection or installation on an actual cost basis, the following conditions shall apply in addition to those as under A:

1. Purchaser shall make payments to supplier according to rates of charge for working hours agreed upon at time of order together with premiums for overtime, night Sunday or holiday work, work under unusually difficult conditions, planning and supervision.
2. Moreover, the following costs shall be paid separately:
 - a) Travelling expenditures, costs for transport of tools and personal luggage.
 - b) Daily allowance for working hours as well as for off-days and holidays.

VIII. Acceptance

1. Goods delivered shall be accepted by Purchaser even if they show minor defects.
2. Partial deliveries are admissible.

IX. Liability for faults

The Supplier shall be liable for faults including failure to achieve assured characteristics as under:

1. The Supplier shall at his discretion repair or replace such part or perform anew such services free of charge as have become of no use or markedly impaired in usefulness within 12 months after transfer of risk, - regardless of actual operating time - owing to circumstances prior to transfer of risk, particularly such as faulty design, materials or workmanship. Supplier must be informed in writing of such faults immediately after they have been noticed.
2. Purchaser has to comply with his contractual obligations, in particular with the agreed conditions of payment. If complaint in respect to a fault is made, Purchaser may withhold payments to an extent, which is fair and reasonable in respect to the faults occurred.

However, if the Contract is entered into pursuant of Purchaser's line of business payments may only be withheld under the condition that the complaint in respect to a fault is justified beyond any reasonable doubt.

3. Purchaser shall grant the Supplier such adequate time and opportunity as Supplier deems reasonable to remedy the faults. In case of refusal supplier's liability shall be waived.
4. If Supplier lets expire an adequate extension of time as set by Purchaser without remedying the fault, Purchaser shall have the right to cancel the contract (cancellation) or claim a reduction of price (reduction).
5. Right of Purchaser to lodge claims owing to faults shall in any case be barred after a period of 12 months has expired beginning from the date of above complaint. If no agreement is reached within this period of time, Supplier and Purchaser may agree to an extension of said period.
6. Liability for faults does not cover natural wear and tear nor damage arising after transfer of risk owing to faulty or negligent handling, excessive strain, unsuitable materials for operation, deficient civil engineering work, unsuitable soil conditions, and such chemical, electrochemical or electrical influences as were not assumed at the time of the Contract.
7. All liability for consequences of any inexperienced alterations or repairs carried out by Purchaser or a third party shall be waived.
8. Period of liability for faults in repairs shall be 3 months, for replacements or renewals 6 months. However, above period shall run at least until expiry of warranty period as originally provided for in respect of the contractual goods.

If parts of supplies cannot be put into efficient operation owing to an interruption of work caused by repairs, replacements or corrected services, period of liability for faults for such parts shall be extended by same period of interruption.

9. The provisions concerning periods of liability for faults under paras 1, 5 and 8 shall not apply where longer periods are enforced by law.
10. Supplier or supplier's agents shall in no event be liable to Purchaser for any further claims, particularly claims for damages not affecting the goods themselves. This shall not apply where liability is enforced by law as in cases of personal injury or of damage to private property pursuant to the Product Liability Act or as in cases of intent, gross negligence, or failure in assured characteristics.
11. Subsection 1 to 10 shall apply accordingly to claims of Purchaser concerning repair, replacement or damages originating from proposals or advice given within the scope of the Contract or originating from a breach of secondary contractual obligations.

X. Impossibility of performance; adjustment of Contract

1. If Supplier or Purchaser are unable to perform their supplies or services, general legal principles shall apply, subject to the following conditions:
If Supplier may be held responsible for inability, Purchaser is entitled to claim damages. However, liability of supplier shall be limited to 10% of the value of

that part of services or supplies which, owing to the inability cannot be put into useful operation. Damages of Purchaser exceeding said margin of 10 % are excluded. This does not apply where liability is enforced by law in cases of intent or gross negligence. The right of Purchaser to cancel the Contract shall remain unaffected.

2. Insofar as unforeseen events as described under Section V, Subsection 3 para 1 materially affect the economic consequences or substance of the supplies or services or have a major effect on Supplier's business, the contract shall be adjusted reasonably with good faith. If this is not justifiable from an economic point of view Supplier may cancel the Contract. If he wishes to exercise this right of cancellation, he shall inform Purchaser of such intention immediately after recognising the significance of the event; this shall apply even where in the first instance an extension of delivery period has been agreed upon with the Purchaser.

XI. Further claims for damages

Claims for damages on the part of the Purchaser arising from breach of secondary contractual obligations, obligations during the stage of contractual negotiations and tort are excluded. This does not apply where liability is enforced by law as in cases of personal injury or of damage to private property pursuant to the Product Liability Act or as in cases of intent or gross negligence. This limitation shall apply accordingly in respect of the Purchaser.

XII. Place of jurisdiction

1. If Purchaser is a company or business man, exclusive place of jurisdiction in case of all litigations arising directly or indirectly out of this contract shall be at the discretion of supplier the domicile of Supplier's head or branch office.
2. Contractual relations shall be governed by German law.

XIII. Validity of Contract

If any provision of this Contract is void the remaining part of the Contract shall remain unaffected. This shall not apply if adherence to the Contract should mean an unreasonable hardship to any one Party.

Die „Allgemeinen Lieferbedingungen für Erzeugnisse und Leistungen der Elektro-Industrie“ erscheinen im Verlag W. Sachon, 87719 Mindelheim, und werden mit dessen freundlicher Genehmigung hier abgedruckt.

©5/93

HARTMANN & KÖNIG
Stromzuführungs GmbH & Co. KG
Graben-Neudorf

Additional Conditions: of Hartmann + König

The springs of cable reeling drums with spring drive are exempt from our guarantee. Whilst we use the best materials for the springs, their wear and tear depends entirely on conditions at site, which are beyond our control.

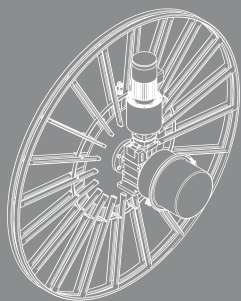

Motorized cable reels

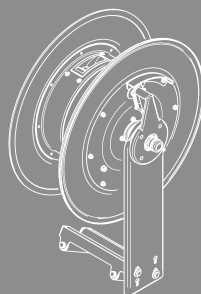

Spring cable reels

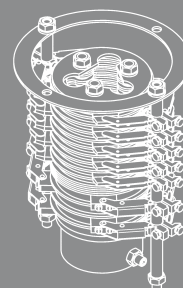

Slip ring bodies

Hartmann & König Stromzuführungs AG
Siemensstraße 6 · 76676 Graben-Neudorf · Germany
Phone +49 7255 7120-0 · Fax +49 7255 5038
info@hukag.com · www.hukag.com

